

International Association for Hydraulics Engineering and Research (IAHR)

## **Fifth International Symposium on Environmental Hydraulics**

4-7 December 2007 Tempe, Arizona, USA.

*Session: History of Environmental Hydraulics*

### **A WEB BASED INFORMATION SYSTEM FOR THE INSPECTION OF THE HYDRAULIC WORKS IN ANCIENT GREECE**

N. Mamassis, V. Kannelopoulos and D. Koutsoyiannis

*Department of Water Resources,*

*School of Civil Engineering,*

*National Technical University of Athens, Greece*

## **Main Topics**

- Purposes of the system
- The ancient Greek hydraulic works
- The application
- Review of the material

## Purposes

*The main purpose of the system is the creation of a basic information pool concerning ancient Greek water knowledge. To achieve this, the available information must be:*

- Gathered and archived
- Codified
- Analyzed using informatics tools to perform queries or to make maps
- Easily accessed from the general public and researchers

*In order to serve this task continuously, the system must be enriched and be extended gradually, incorporating new findings.*

## The ancient Greek hydraulic works

Ancient societies that flourished on the Greek territory, held an exceptional position to the use and management of water resources because they:

- applied advanced technologies in the construction of several hydraulic works
- adopted sustainable water management practices
- developed high living standards related to water use
- devised explanations about the natural hydrometeorological phenomena

## **The ancient Greek hydraulic works**

*Using hydraulic technologies combined with understanding of processes, ancient Greeks supported several needs such as the:*

- urban and irrigation water supply
- urban and land drainage
- flood protection
- sanitary facilities
- use of water for recreational purposes

*As a result of a four thousand years creative activity, several hydraulic structures are spread all over the wider ancient Greek territory*

- simple structures (cisterns, lavatories, wells, aqueducts, pipes, sedimentation tanks)
- advanced structures (dams, tunnels, siphons)

*Also in ancient literature there are numerous references about:*

- sustainable water management practices
- hydraulics works that are not preserved till today
- impressive exegeses about hydrometeorological processes (e.g. evaporation, condensation, hail, snow, rain)

# The ancient Greek hydraulic works

## Sources of information and codification

A considerable amount of the knowledge about hydraulic works and water management practices developed in ancient Greece can be found in

- Papers (journals, conferences)
- Reports
- Photos-videos

The above information is retrieved and then codified mainly by

- Geographical location (using a GIS)
- Construction period (Minoan, Mycanean, Archaic, Classical, Hellenistic, Roman)
- Type (cisterns, lavatories, wells, aqueducts, dams, siphons etc.)
- Use (water supply and drainage, flood protection, sanitary facilities etc.)

# Application

## Features not included

Currently, the application does not include features such as:

- Harbors, because there is a dedicated application for them (*Limenoscope*)
- Water management practices (including gray water use) that were applied in several Greek cities. Their descriptions can be found in the classical literature, and in many cases have been expressed in a law or a directive
- Physical explanations of natural phenomena that had a relationship with the hydraulic works
- Hydraulic devices and mechanisms that were invented and were applied to water transportation. An exceptional example is the pump of Archimedes, a device still in use today

# Application

## General scheme

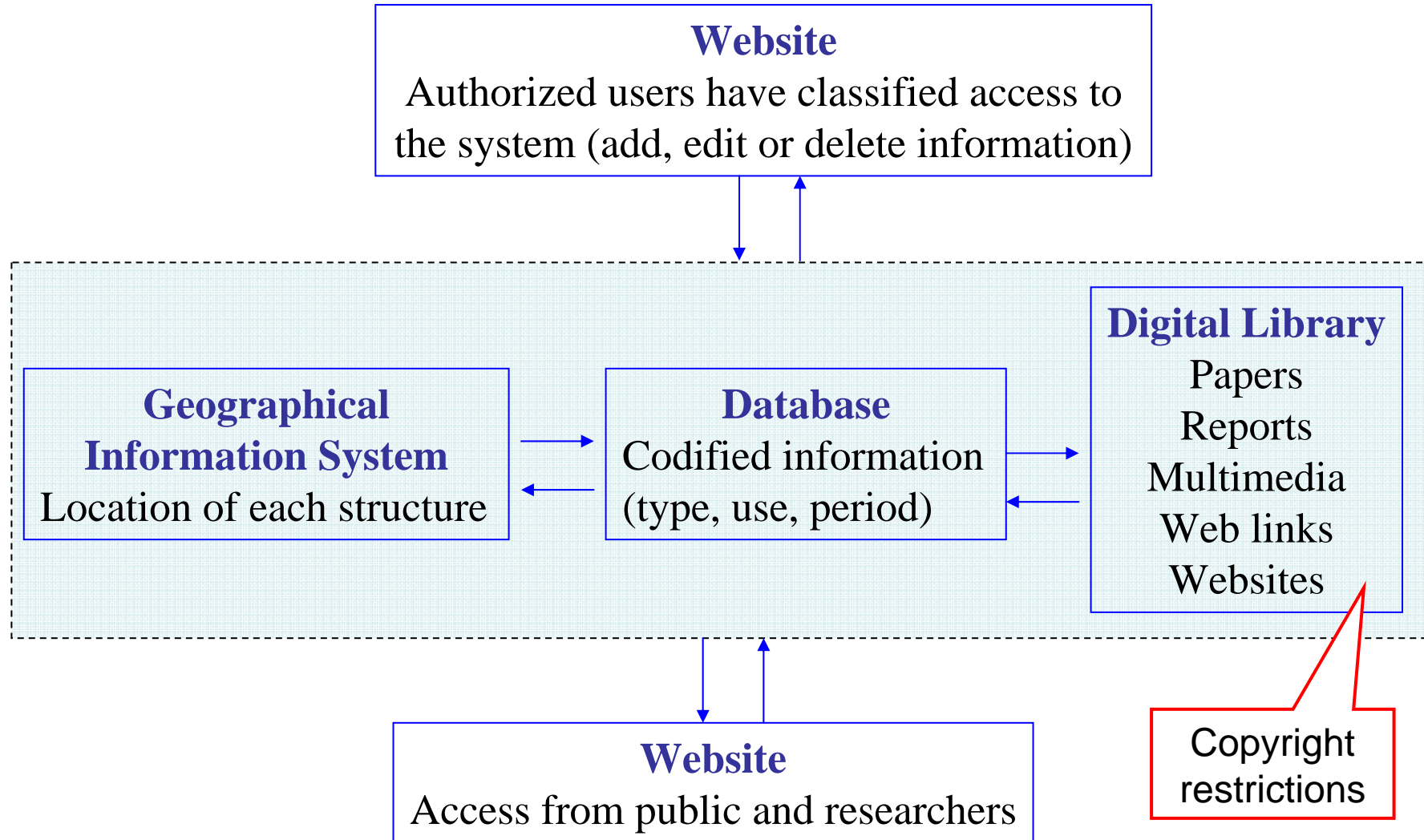



# Application

## Web site using open technologies

- Python programming language
- Django web application framework
- PostgreSQL database
- Apache web server
- Debian GNU/Linux operating system
- <http://www.openwebdesign.org/>

## Django automates most of the tasks

- 120 lines of Python code
- 107 lines of HTML templates and that's it! (but of course you need the programmer)

# Application

Geographical  
Information  
System

Hydraulic works

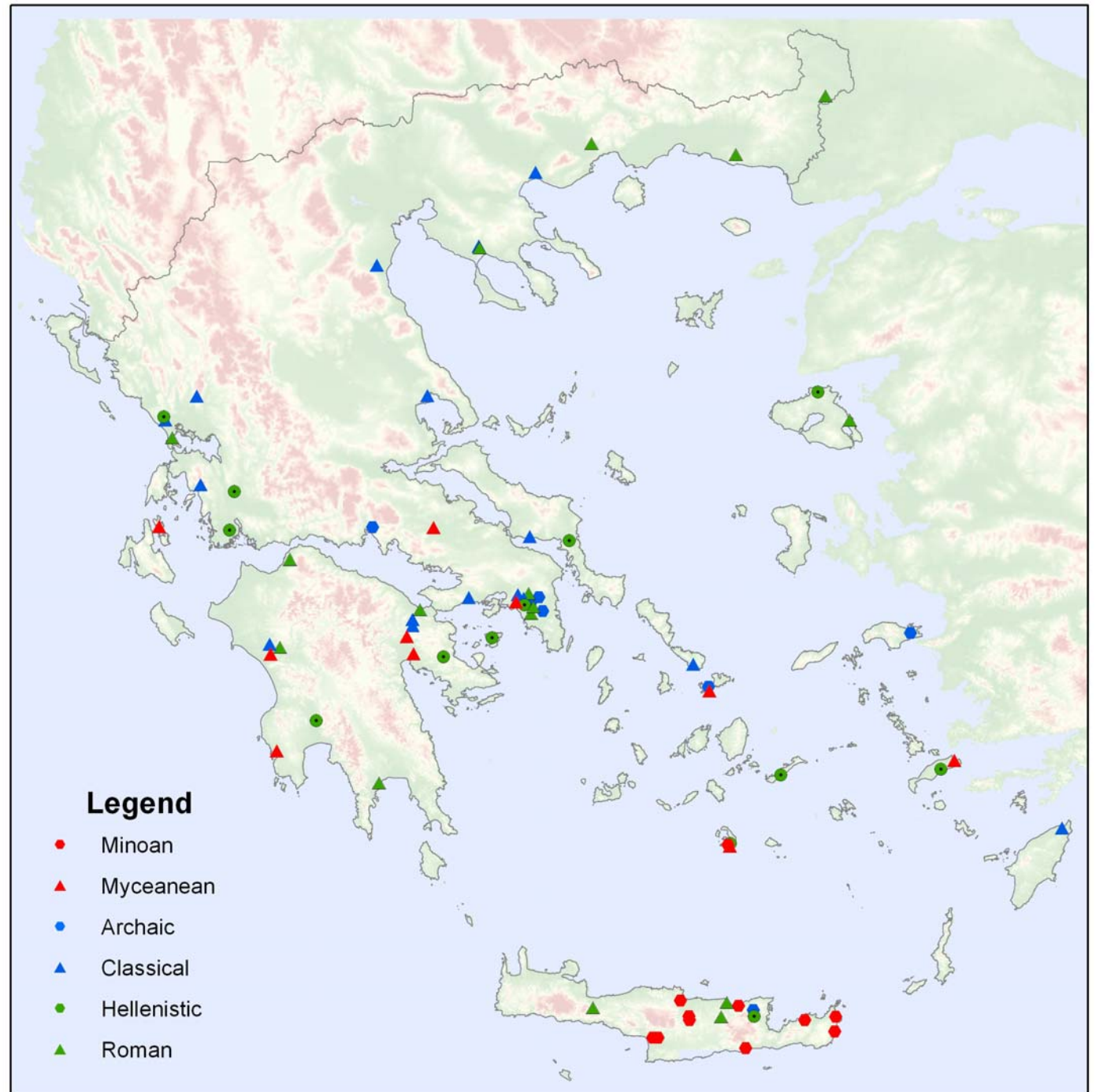

# Application

Geographical  
Information  
System

## Aqueducts

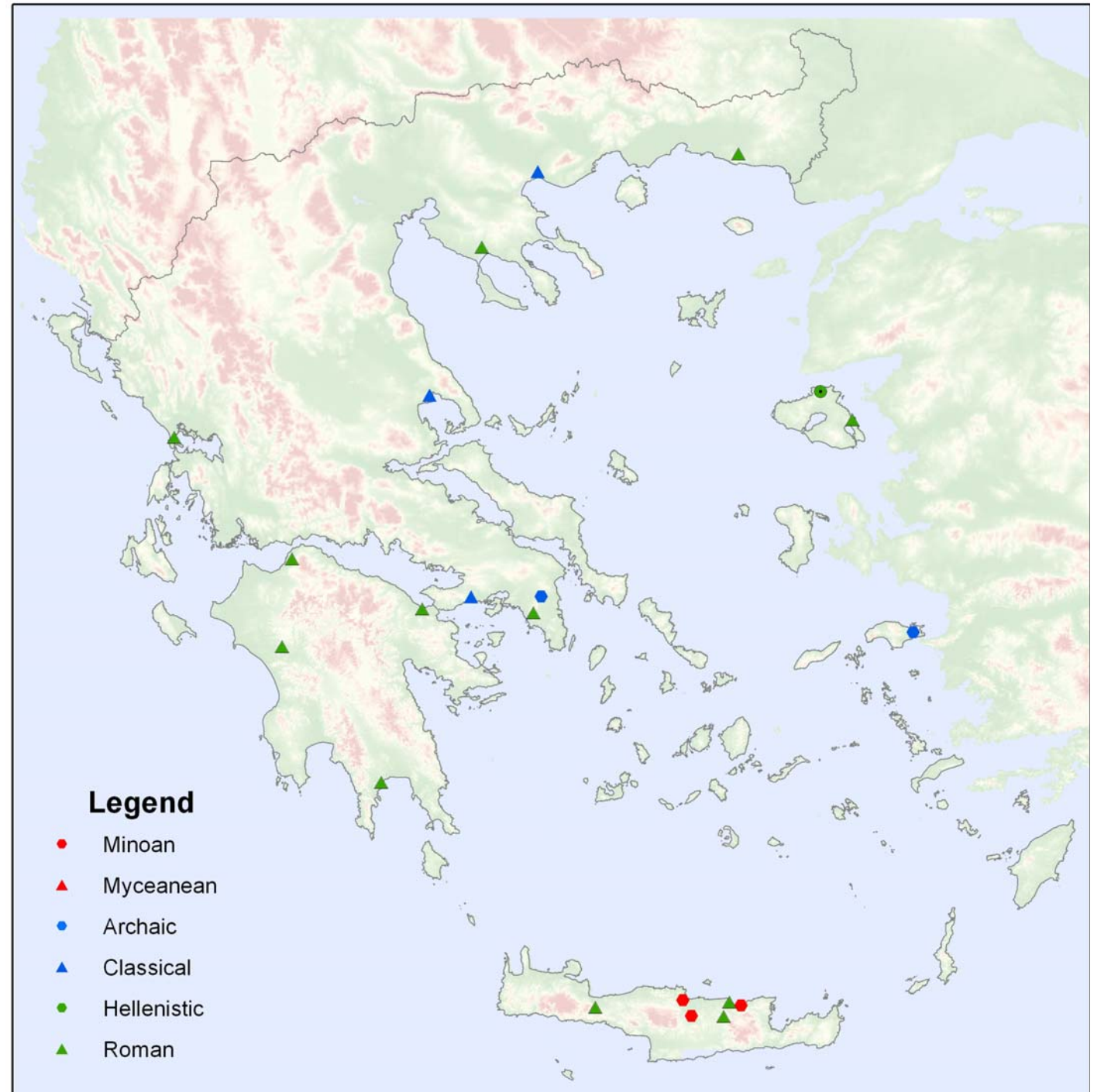

# Application

Geographical  
Information  
System

## Lavatories

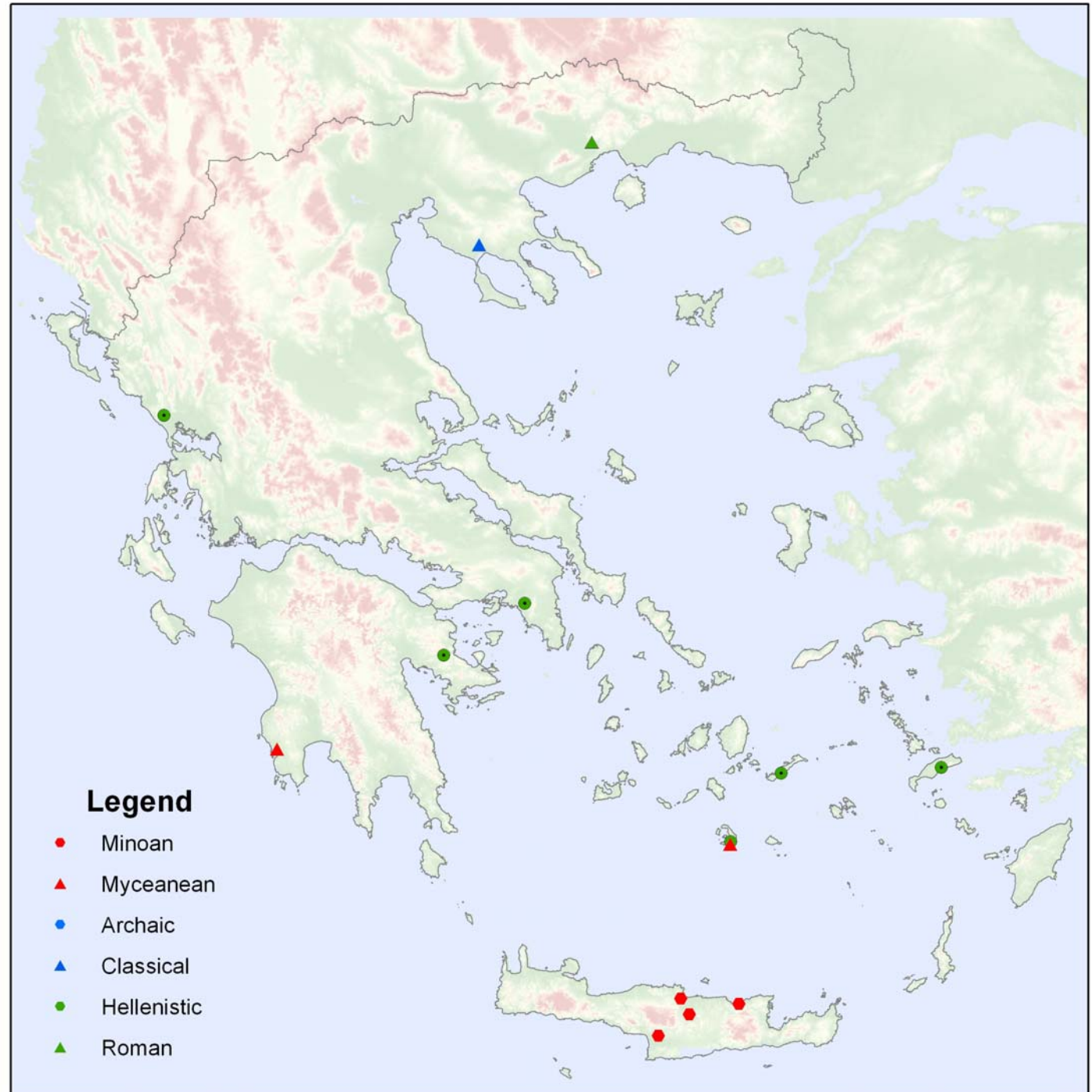

# Application

**Website:** [/www.itia.ntua.gr/nikos/AncientWorks/index.htm](http://www.itia.ntua.gr/nikos/AncientWorks/index.htm)

## INFORMATION SYSTEM OF ANCIENT GREEK HYDRAULIC WORKS

[GENERAL INFORMATION](#)

[MAP](#)

[DATABASE](#)

[LINKS](#)

[CONTACT](#)



Department of Water Resources and Environmental Engineering

School of Civil Engineering

National Technical University of Athens-GREECE

# Application

## Website-Selection through map and table

Using DB (two levels for authorized users and general public)

Using GIS map (for general public)

Φίλτρο	List of ancient hydraulic works																																																											
<b>Ανά construction era</b>	97 works																																																											
<input type="checkbox"/> Όλα <input type="checkbox"/> Minoan-Cycladic <input type="checkbox"/> Mycenaean <input type="checkbox"/> Archaic <input type="checkbox"/> Classical <input type="checkbox"/> Hellenistic <input type="checkbox"/> Roman	<a href="#">Aegina cistern</a> <a href="#">Alysia dam</a> <a href="#">Amorgos Lavatory</a> <a href="#">Amphipolis aqueduct</a> <a href="#">Amphipolis sewage</a> <a href="#">Archanes cistern</a> <a href="#">Athens agora</a> <a href="#">Athens Archaic cisterns</a> <a href="#">Athens Ceramikos</a> <a href="#">Athens Clepsydra</a> <a href="#">Athens Enneakrounos</a> <a href="#">Athens fountain</a> <a href="#">Athens Lavatory</a> <a href="#">Athens Peisistratean aqueduct</a> <a href="#">Athens Roman cisterns</a> <a href="#">Cassope lavatory</a> <a href="#">Cassope sewers</a> <a href="#">Chamaizi cistern</a> <a href="#">Corinth aqueduct</a> <a href="#">Delos cistern</a> <a href="#">Delos lavatory</a> <a href="#">Demetriada aqueduct</a> <a href="#">Dion sewer</a> <a href="#">Dreros cistern</a> <a href="#">Epidaurus lavatory</a> <a href="#">Eretria sewer</a> <a href="#">Evpalinean aqueduct</a> <a href="#">Glayki fountain</a> <a href="#">Hadrianean aqueduct</a>	<table border="1" style="width: 100%; border-collapse: collapse;"> <thead> <tr> <th style="text-align: left;">Use</th> <th style="text-align: left;">Const</th> </tr> </thead> <tbody> <tr><td>urban water supply</td><td>Hellen</td></tr> <tr><td>flood prevention</td><td>Classi</td></tr> <tr><td>urban sewage</td><td>Hellen</td></tr> <tr><td>urban water supply</td><td>Classi</td></tr> <tr><td>urban drainage</td><td>Classi</td></tr> <tr><td>urban water supply</td><td>Minoa</td></tr> <tr><td>urban drainage</td><td>Classi</td></tr> <tr><td>urban water supply</td><td>Archa</td></tr> <tr><td>urban drainage</td><td>Classi</td></tr> <tr><td>urban water supply</td><td>Classi</td></tr> <tr><td>urban water supply</td><td>Archa</td></tr> <tr><td>urban water supply</td><td>Mycar</td></tr> <tr><td>sanitary facilities</td><td>Hellen</td></tr> <tr><td>urban water supply</td><td>Archa</td></tr> <tr><td>urban water supply</td><td>Roma</td></tr> <tr><td>sanitary facilities</td><td>Hellen</td></tr> <tr><td>urban drainage</td><td>Classi</td></tr> <tr><td>urban water supply</td><td>Minoa</td></tr> <tr><td>urban water supply</td><td>Roma</td></tr> <tr><td>urban drainage</td><td>Hellen</td></tr> <tr><td>urban water supply</td><td>Classi</td></tr> <tr><td>urban drainage</td><td>Classi</td></tr> <tr><td>urban water supply</td><td>Archa</td></tr> <tr><td>urban drainage</td><td>Hellen</td></tr> <tr><td>urban drainage</td><td>Classi</td></tr> <tr><td>urban water supply</td><td>Classi</td></tr> <tr><td>urban water supply</td><td>Classi</td></tr> <tr><td>urban water supply</td><td>Roma</td></tr> </tbody> </table>	Use	Const	urban water supply	Hellen	flood prevention	Classi	urban sewage	Hellen	urban water supply	Classi	urban drainage	Classi	urban water supply	Minoa	urban drainage	Classi	urban water supply	Archa	urban drainage	Classi	urban water supply	Classi	urban water supply	Archa	urban water supply	Mycar	sanitary facilities	Hellen	urban water supply	Archa	urban water supply	Roma	sanitary facilities	Hellen	urban drainage	Classi	urban water supply	Minoa	urban water supply	Roma	urban drainage	Hellen	urban water supply	Classi	urban drainage	Classi	urban water supply	Archa	urban drainage	Hellen	urban drainage	Classi	urban water supply	Classi	urban water supply	Classi	urban water supply	Roma
Use	Const																																																											
urban water supply	Hellen																																																											
flood prevention	Classi																																																											
urban sewage	Hellen																																																											
urban water supply	Classi																																																											
urban drainage	Classi																																																											
urban water supply	Minoa																																																											
urban drainage	Classi																																																											
urban water supply	Archa																																																											
urban drainage	Classi																																																											
urban water supply	Classi																																																											
urban water supply	Archa																																																											
urban water supply	Mycar																																																											
sanitary facilities	Hellen																																																											
urban water supply	Archa																																																											
urban water supply	Roma																																																											
sanitary facilities	Hellen																																																											
urban drainage	Classi																																																											
urban water supply	Minoa																																																											
urban water supply	Roma																																																											
urban drainage	Hellen																																																											
urban water supply	Classi																																																											
urban drainage	Classi																																																											
urban water supply	Archa																																																											
urban drainage	Hellen																																																											
urban drainage	Classi																																																											
urban water supply	Classi																																																											
urban water supply	Classi																																																											
urban water supply	Roma																																																											
<b>Ανά use</b>																																																												
<input type="checkbox"/> Όλα <input type="checkbox"/> urban water supply <input type="checkbox"/> irrigation water <input type="checkbox"/> supply <input type="checkbox"/> urban drainage <input type="checkbox"/> land drainage <input type="checkbox"/> urban sewage <input type="checkbox"/> flood prevention <input type="checkbox"/> sanitary facilities																																																												
<b>Ανά type</b>																																																												
<input type="checkbox"/> Όλα <input type="checkbox"/> aqueduct <input type="checkbox"/> cistern <input type="checkbox"/> well <input type="checkbox"/> fountain <input type="checkbox"/> lavatory <input type="checkbox"/> bathtub <input type="checkbox"/> siphon <input type="checkbox"/> tunnel <input type="checkbox"/> water distribution <input type="checkbox"/> system <input type="checkbox"/> sedimentation tank <input type="checkbox"/> dam <input type="checkbox"/> stream control																																																												

[GENERAL INFORMATION](#)    [MAP](#)    [DATABASE](#)    [LINKS](#)    [CONTACT](#)

# Review of the material

## Issues for a further discussion

### Cooperation of different structures as a hydrosystem

In many important sites several hydraulic works operated as a hydrosystem. Legislation, institutions and public awareness about water strongly supported hydrosystem's operation.

- The Minoan palace sites (Knossos, Zakros, Mallia)
- The city of Athens from Archaic to Roman period

### Technological achievements

Even today, several structures are admirable engineering solutions.

- The [Tunnel of Eupalinos](#) in Samos
- The [inverted siphon](#), a component of the Pergamon aqueduct.

### Relation of the implemented technology with socio-economical characteristics of the societies

During some periods, the political situation favored the construction of large public works (such as the [Peisistratean](#) aqueduct in Athens). On the other hand, during the democracy period in Athens, smaller constructions were preferred for collecting the storm water

### The small facilities that improved the quality of life

Several small scale facilities (lavatories, bathtubs), related to water use can easily be compared with the modern ones. It is worth mentioning that the [toilets of Knossos palace](#) had seats, flushing equipment and were connected to sewers.

## Conclusions

- An information system is developed to support the scientific and public research about ancient Greek engineering practices
- Up to this moment the system contains information about 100 important hydraulic works of several types and magnitude
- A quick view of the gathered information reveals that ancient Greeks effectively tackled several water problems that modern societies still have to face up
- Future tasks include:
  - the enrichment of the system with more hydraulic works
  - the codification of water management practices and hydraulic devices
  - the expansion of the information in space and time



# Eupalinean aqueduct

The most famous hydraulic work of ancient Greece was the aqueduct of ancient Samos, which was admired both in antiquity and in modern times. The most amazing part of the aqueduct is the “Eupalinean digging”, a 1036 m long tunnel the first known deep tunnel in history. Eupalinos an engineer from Megara dug the tunnel from two openings, a very modern practice. He also solved several technical problems as carving segments on straight lines, eliminating the impact of uncertainty in position, and ensuring the hydraulic gradient to sustain flow in the aqueduct. Its construction started in 530 BC, during the tyranny of Polycrates and lasted for ten years.

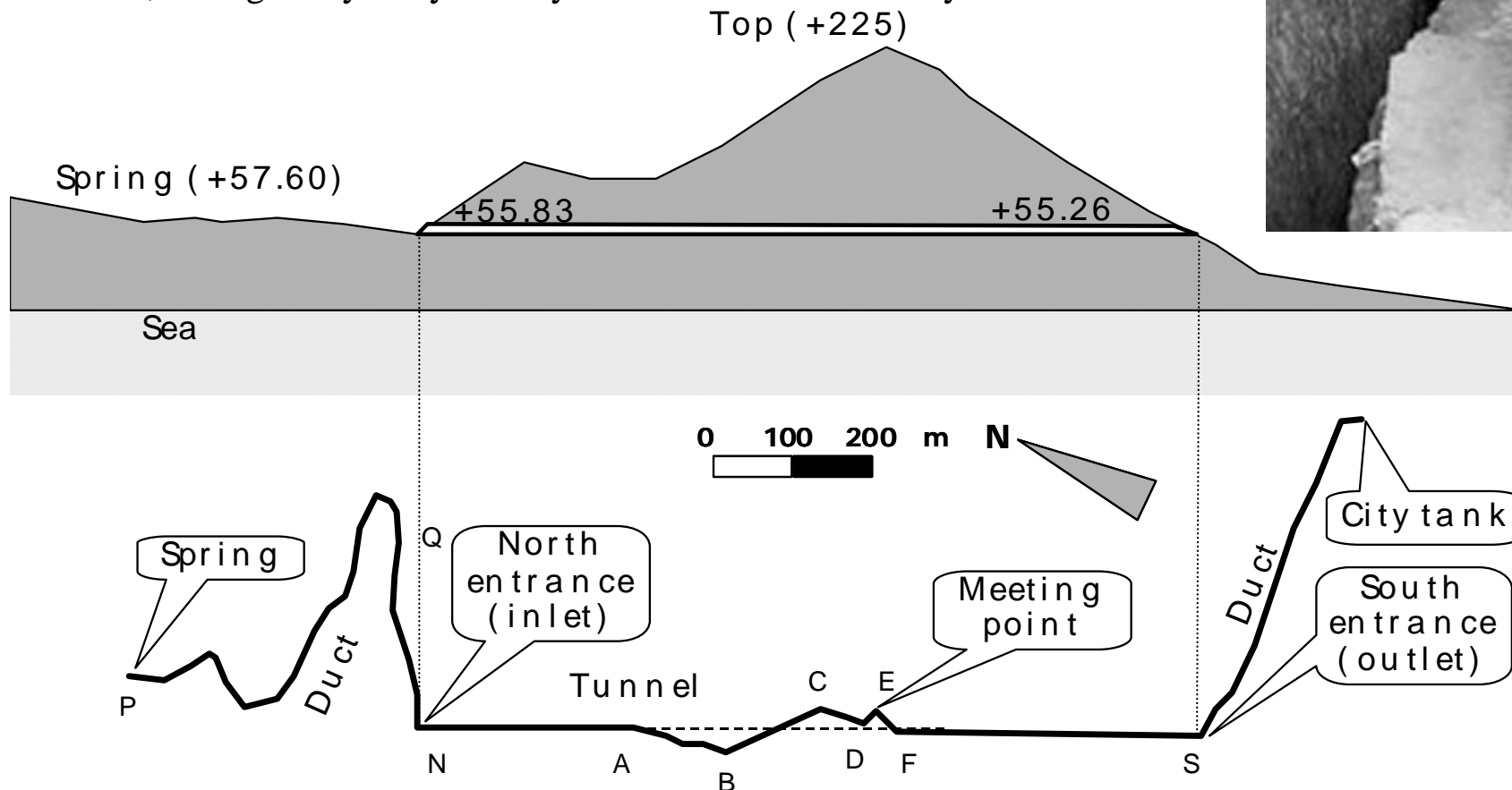

# The Pergammon aqueduct

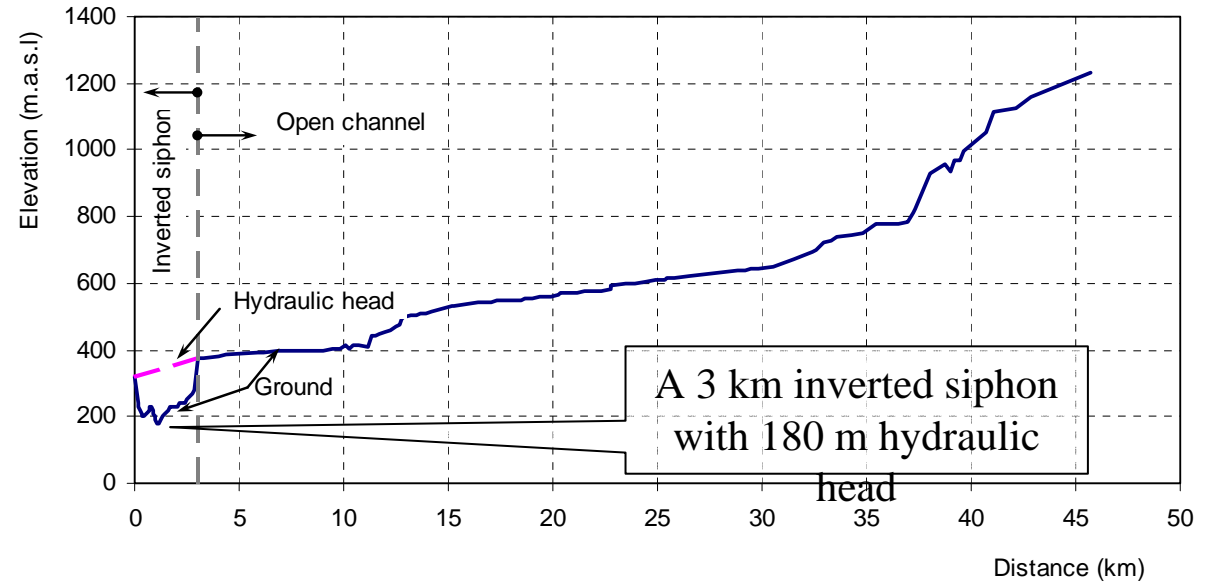

It was constructed around 200 BC with length that exceeds 3000 m and it is the first large scale application where water was transported with flow under pressure.

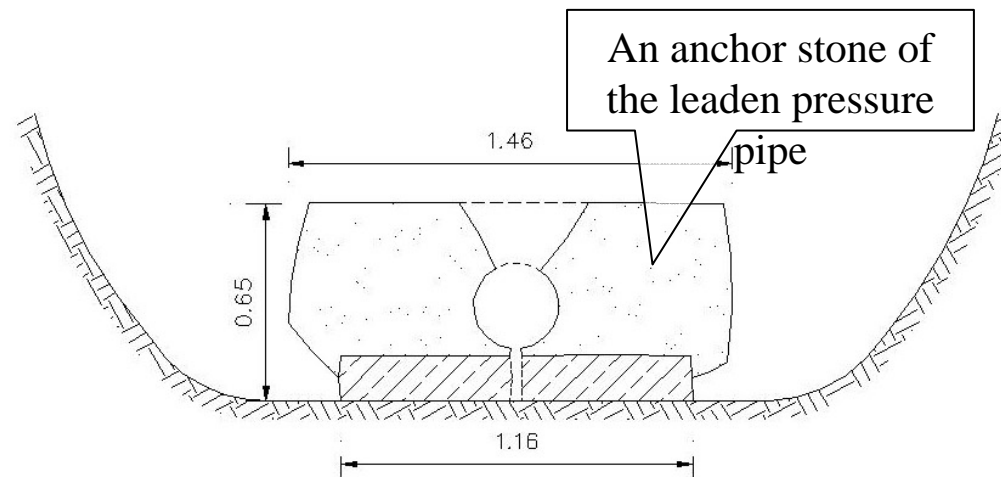

# The Peisistratean aqueduct

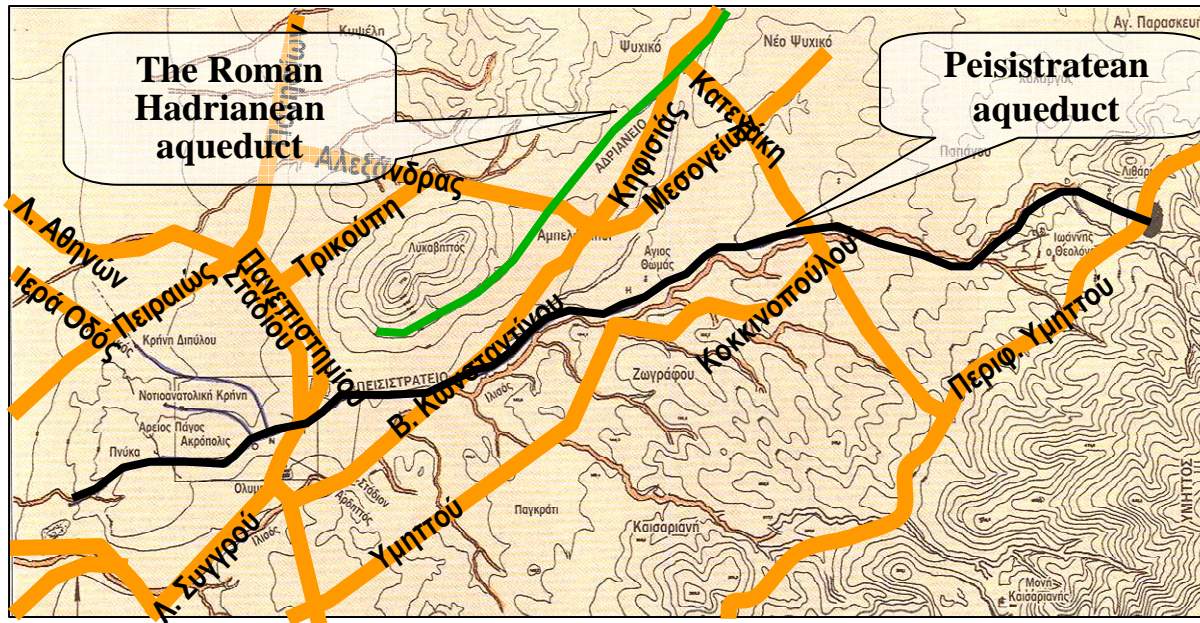

The first major hydraulic project in Athens was constructed under the tyrant Peisistratos (in power between 546-527 BC) and his sons. Mostly carved as a tunnel at a depth reaching 14 m.

Ceramic pipeline at the bottom.

Greek hydraulic constructions were mostly subterranean for security reasons (not no be exposed to aliens, e.g. in case of war)

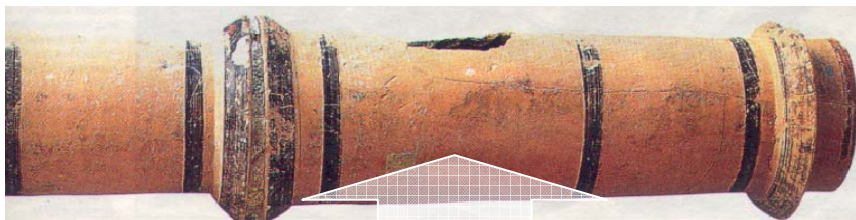

Part of the Peisistratean aqueduct and detail of the pipe sections and their connection (photos reproduced from newspaper Kathimerini).



## Minoan toilets

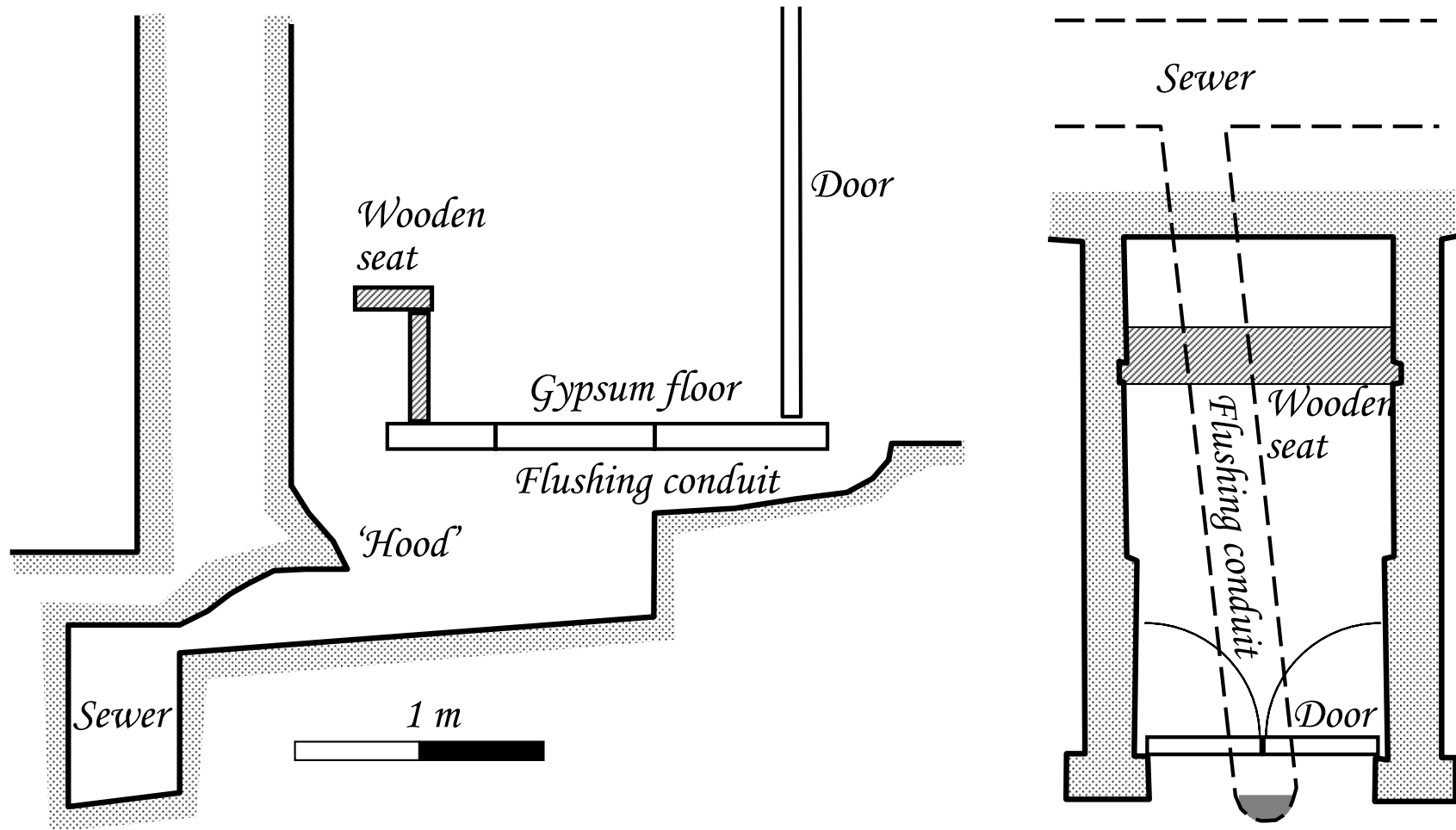

Section and plan of ground-floor toilet in the residential quarter of Palace of Minos (Graham, 1987).

