

A groundwater-based, objective-heuristic parameter optimisation method for a precipitation-runoff model and its application to a semi-arid basin

K. Mazi¹, A. D. Koussis^{1*}, P. J. Restrepo² and D. Koutsoyiannis³

¹ Institute for Environmental Research & Sustainable Development, National Observatory of Athens
I. Metaxa & Vas. Pavlou, GR - 15236 Palea Penteli, Athens, Greece

² Optimal Decision Engineering Corporation, 1002 Walnut St., Suite 200, Boulder,
Colorado 80302, USA

³ Department of Water Resources, National Technical University of Athens
Heron Polytechniou 5, GR - 157 80 Zographou, Athens, Greece

Abstract

A hydrologic model calibration methodology that is based on groundwater data is developed and implemented using the USGS precipitation-runoff modelling system (PRMS) and the modular modelling system (MMS), which performs automatic calibration of parameters. The developed methodology was tested in the Akrotiri basin, Cyprus. The necessity for the groundwater-based model calibration, rather than a typical runoff-based one, arose from the very intermittent character of the runoff in the Akrotiri basin, a case often met in semiarid regions. Introducing a datum and converting groundwater storage to head made the observable groundwater level the calibration indicator. The modelling of the Akrotiri basin leads us to conclude that groundwater level is a useful indicator for hydrological model calibration that can be potentially used in other similar situations in the absence of river flow measurements. However, the option of an automatic calibration of the complex hydrologic model PRMS by MMS did not ensure a good outcome. On the other hand, automatic optimisation, combined with heuristic expert intervention, enabled achievement of good calibration and constitutes a valuable means for saving effort and improving modelling performance. To this end, results must be scrutinised, melding the viewpoint of physical sense with mathematical efficiency criteria. Thus optimised, PRMS achieved a low simulation error, good reproduction of the historic trend of the aquifer water level evolution and reasonable physical behaviour (good hydrologic balance, aquifer did not empty, good estimation of mean natural recharge rate).

Keywords: groundwater, hydrologic model, parameter estimation, automatic calibration, natural recharge

* Corresponding author: akoussis@env.meteo.noa.gr, tel.: +30-210-810 9125, fax: +30-210-810 3236

1. Introduction

The basis of a management plan for the water resources of a basin is the evolution of its hydrologic balance, estimated through mathematical model simulations. Use of models has become a standard task in hydrologic practice. Their results are credible, provided that model structure is appropriate and parameter values are determined such that model output and observations agree within close margins (calibration and validation). Typically, the calibration/validation indicator is the basin's surface runoff; in semiarid regions, however, surface runoff is often only ephemeral and thus not a suitable indicator. Because, generally, simple models rely more on output observations for calibration than complex ones (e.g. *Refsgaard and Knudsen, 1996*), parameter calibration requirements and data availability are important issues in model selection. For example, calibration of a black box model relies entirely on output observations; a physically based model poses fewer such demands, but even the largely physically based SHE model requires calibration (*Refsgaard, 1997*).

Time series of the natural recharge of the Akrotiri aquifer in Cyprus were needed in a case study of the *WASSER* project (*Koussis, ed., 2000; Koussis et al., 2002*). The *WASSER* concept optimises water extraction from a coastal aquifer by controlling seawater intrusion through targeted injection of treated wastewater, opting for desalination of brackish water as alternative to expensive seawater desalination. The aquifer's recharge was estimated from the hydrologic balance of the Akrotiri basin, shown in Fig. 1. This hydrologic system is important for Cyprus. It provides water for the supply of the city of Limassol, of the British bases and of several smaller communities in the area as well as for the region's agriculture. In this work, we had to cope with the fact that the semiarid climate of the southeastern Mediterranean and the, mostly, highly permeable geologic formations of the Akrotiri peninsula have shaped a poorly developed surface drainage network. Measurements of the ephemeral surface runoff were lacking, hence a typical model calibration was not feasible.

We therefore developed an alternative model calibration methodology that relies on the use of groundwater data, instead of streamflow data. The hydrologic basin has an area of 78 km², around 40 km² of which are occupied by the main Akrotiri aquifer. The aquifer lies in the southern edge of the basin, but extends to the west slightly outside of the basin, west of the Kouris River. The resources of the main Akrotiri aquifer are exploited intensely (pumping ~ 10 hm³/yr). Earlier studies, e.g. *Jacovides* (1982), concern the time prior to the construction of the Kouris dam and assess its future hydrologic impacts. In response to declining hydraulic heads and attendant seawater intrusion, the Water Development Department (WDD) of the Republic of Cyprus initiated artificial recharge of the aquifer. WDD maintains a substantial database, which was made available for setting up the model.

As basic modelling tool we used the US Geological Survey's (USGS) *Precipitation Runoff Modelling System* (PRMS) (*Leavesley et al.*, 1983, *Leavesley and Stennard*, 1995), which we modified appropriately. PRMS is operated within the USGS *Modular Modelling System* (MMS) (*Leavesley et al.*, 1996, 2002). Parameters were calibrated in two stages, first using automatic optimisation and then steering the process manually for final fit. MMS can be linked to the GIS software GRASS through a suitable interface and has user-friendly facilities for data input and for output visualisation and an ArcInfo-based pre-processor (*Viger et al.*, 2001) for estimating those parameters that are physically observable.

This paper summarises the work reported by *Mazi* (2000) and is structured as follows. The scope of work is stated in section 2. In section 3, we present PRMS briefly, outlining our enhancements of the code, and detail the modelling methodology. Section 4 refers to the Akrotiri case study and comprises the main body of the work. It summarises the physical conditions and the data on input and output variables of the system and focuses on the parameter calibration methodology and on the modelling results. The results are appraised in section 5. The paper closes with section 6, Conclusions.

2. Scope of Work

Beyond the actual water resources engineering, the research objectives of the work were twofold: 1) development of a calibration methodology based on groundwater data and 2) assessment of the MMS capability for automatic calibration of PRMS. Traditionally, calibration of watershed models has been based on streamflow measurements. However, such measurements are costly and for this reason only a small, and decreasing number of catchments are gauged worldwide. Data collection activities are being curtailed, even in developed countries such as the USA (Adams, 2002). Given this situation, the International Association of Hydrological Sciences (2002) has declared hydrological data “an endangered species” and has commenced the international research initiative on Prediction in Ungauged Basins (PUB). Moreover, in semiarid areas, the ephemeral nature of surface runoff makes metering of streamflow most of the time impossible. Therefore, alternative methodologies, based on different, less costly data, should be sought in such real-world cases where streamflow or its records are absent. From this perspective, measurements of groundwater level are examined here as potential basis for watershed model calibration.

The procedure of automatic optimal parameter estimation is attractive due to its objectivity, as the model itself is used to determine changes in the parameter values through non-linear regression (Hill, 1992). A heuristic calibration of a complex model is generally recognised as a tedious and time-consuming task, normally reserved for experts. On the other hand, difficulties in the optimisation such as local minima traps are expected, since this inverse problem is ill-posed (non-unique solution). Furthermore, Gupta *et al.* (1998) show that (a) different objective functions result in different optimal parameter sets, (b) the output is matched piecewise better by different optimal models and (c) optimal parameters vary when calibrated on different portions of the output record; (c) and possibly (a) suggest imperfect model structure [e.g., Bras and Restrepo-Posada (1980); Bras and Rodríguez-Iturbe (1985)]. Despite their promise, early experience with automatic optimisation methods led one to

expect modest modelling performance, due to unreliable calibration, in stark contrast to the excellent results that experts achieve through the classical, manual approach (*Sorooshian and Gupta, 1995*). Recent advances (e.g. *Yapo et al., 1998; Gupta et al., 1999; Madsen et al., 2002; Madsen, 2003*) show that, to match an expert manual calibration, automatic optimisation must include multiple objectives and exploit prior information.

Considering that a combined approach offers the best prospects for the use of the multi-parameter PRMS, we decided to take advantage of the ease offered by the automatic calibration tools of MMS, accepting that the optimisation results would have to be scrutinised and the final search be guided heuristically using multiple optimality measures (e.g., *Gupta et al., 1998; Madsen, 2000*). This combined approach shares methodological features with those of *Lindström (1997)* and of *Boyle et al. (2000)*.

3. Modelling Framework, Concept and Tools

PRMS is a distributed conceptual hydrologic model, originally developed as a stand-alone model for mainframe computers. To take advantage of the modularity support and other facilities furnished by MMS, PRMS was re-coded in a modular format that facilitates modifications (*Leavesley et al., 1995*). Its modularity and the availability (via MMS) of an automatic, objective parameter estimation facility were important considerations in our model selection. PRMS cannot belie its surface hydrology orientation, which is focused on the supply of streams, as seen in Fig. 2. A basin is divided in surface elements of uniform hydro-morphologic properties, termed hydrologic response units, HRU, shown e.g. in Fig. 1. Temporal integration is carried out in daily steps. Output can be aggregated in space and time as needed. As Fig. 3 indicates, representation of the surface and shallow subsurface processes (soil to groundwater) is detailed, but the aquifer simulation part is inherently simple, mainly because any groundwater reservoirs used are not inter-connected.

This assessment led us to expect that the supply of the groundwater reservoir could be estimated reasonably. Re-coding would be required to enable model calibration on groundwater observations, but should be minor. The undertaken modifications were as follows. First, we added the calculation of level changes in the groundwater reservoirs in response to artificial recharge and to pumping (the original code considers only natural recharge). Reservoir storage per unit area was converted to groundwater column through division by a *porosity* parameter, a substitute for the specific yield in the context of representing the aquifer by a *conceptual* reservoir. Then, positioning of the groundwater column relative to a datum, as shown in Fig. 4, allowed using the observable groundwater level as calibration indicator. Computed groundwater levels could be thus compared to recorded mean levels of the main Akrotiri aquifer, establishing an objective function. These modifications added the porosity and the datum as parameters for optimisation.

The model concept focused on the exploited, main Akrotiri aquifer, for which a substantial amount of good-quality data exists. The aquifer was represented by only two reservoirs, one comprising its non-productive, thin, northern part (for which no water level data exist) and the other the productive main aquifer. PRMS treats these reservoirs as linear and unconnected hydraulically. We consider linearity an approximation compatible with the simple conceptual groundwater modelling of PRMS. However, the lack of communication between the reservoirs constitutes an obvious over-simplification of the natural system's behaviour, especially since the main aquifer receives substantial inflows from adjacent aquifer units. This link had therefore to be established, but via an operationally adequate approximation with the least possible intervention in the code.

To this end a fictitious HRU was added to capture the inflows from: a) the northern-most HRUs 1 and 2, b) the non-productive northern aquifer unit, c) the Kouris reservoir losses and d) the aquifer portion near Kouris River, which lies to the west and outside the limits

of the basin. These inflows were estimated from separate water balance calculations for the HRUs to the north and by adjustment of data of the period 1967-1977 to conditions in the relatively dry period 1989-1999 for the Kouris River. Inflow volumes were finally converted to equivalent rainfall depths and assigned to a rain gauge in the fictitious HRU.

In view of the complexity of the problem and of the tools devised, we considered a good reproduction of the historical *trend* of the mean groundwater level (monthly data from 41 wells, giving roughly ~ 1 well/km²), with simultaneous achievement of a modest absolute error in the estimation of the mean groundwater level and reasonable overall physical behaviour, as indication of success of the proposed approach.

We note in this context that it is feasible to assign to each HRU a separate groundwater reservoir (if geologically justified) and be thus nominally able to assess model predictions against distributed groundwater level data. Yet, aside from the significant increase of parameters, for such modelling detail to be effective, the reservoirs would have to be interconnected hydraulically, which in PRMS they are not. Such a major modification of the PRMS code, or addition of a module for the numerical simulation of transient subsurface flow on the basis of hydraulic equations, was beyond the scope of our study.

4. Case study

4.1. The Physical System

The study area has a surface of $A = 78$ km² and a smooth and hilly relief, with an average altitude in the northern part of the basin over 200 m above MSL. The main aquifer covers 37 km² of the basin area. The geologic section in Fig. 5 indicates that its impermeable base (alternating marls, chalks, chalky marls and marly chalks) slopes towards the south and its saturated thickness ranges from 10 m (water table at 50 m above MSL) at its northern edge to more than 100 m near the Salt Lake in the south. As shown in Fig. 1, the Akrotiri basin is contained between the rivers Kouris to the west and Garyllis to the east; the underlying

aquifer consists of river deposits. The Salt Lake, located in the middle of the peninsula, is a topographic low that serves as an internal drainage basin. The mean water level in the lake is below sea level, but the lake dries completely in the summer.

For the period 1968-2000, the mean annual precipitation over the basin ranges from over 500 mm at its north end to 420 mm near the Salt Lake. The Akrotiri aquifer is replenished by a) rainfall, b) Kouris reservoir losses, c) releases from the Kouris dam, d) inflows from its northern boundary, e) agricultural return flows and f) artificial recharge (effluents from Limassol's wastewater treatment plant and water from the Garyllis and Yermasogia reservoirs, located outside the basin). In an effort to limit saltwater intrusion, artificial recharge was applied to spreading grounds and ponds in the main aquifer area, when water from the external sources was available. Almost no artificial recharge took place during the drought years 1998 and 1999, however pumping was also reduced.

For the application of PRMS, the basin area was divided, initially, in 11 HRUs, four large ones (total $A \approx 76 \text{ km}^2$) and seven small ones. HRU1 includes the northern, wedge-shaped and highest part of the basin ($A = 19 \text{ km}^2$, elevation = 250 m above MSL) that has sparse shrub vegetation and is underlain by the semi-pervious Pahnna formation, where no aquifer develops. Immediately to its south is located HRU2 ($A = 22.3 \text{ km}^2$, elevation = 100 m above MSL), which is also covered sparsely with low vegetation. Its stratigraphy (alternating beds of gravely sands and clays) however allows the formation of a thin aquifer (thickness 0-10 m) of moderate transmissivity, in which the hydraulic slope is $\sim 1.5\%$. HRUs 1 and 2 were linked to the same groundwater reservoir, as shown in Fig. 6.

All HRUs located to the south of HRUs 1 and 2 are underlain by the intensively exploited Akrotiri aquifer and were modelled as connected to the same groundwater reservoir (see Fig. 6). HRU3 ($A = 1.14 \text{ km}^2$) and HRU4 ($A = 13.3 \text{ km}^2$) correspond to agricultural areas; HRU3 (greenhouses) is irrigated from fall to spring and HRU4 (citrus plantations) from

spring to fall. HRU11 ($A = 21.7 \text{ km}^2$) has only sparse, natural vegetation. The remaining HRUs were created to model specific features of the basin. HRUs 5-8 ($A_{\text{total}} = 45 \text{ ha}$) model recharge ponds designed to improve the state of the aquifer; HRU9 ($A = 20 \text{ ha}$) represents the Livadi wetland. Finally, HRU10 ($A = 1 \text{ km}^2$) is the mathematical construct invented to establish the connection between the northern and western parts of the Akrotiri aquifer with the main aquifer and to thus account for the inflows to that groundwater reservoir.

4.2 Input Data, Model Parameters and Output

The time step in which PRMS executes is controlled by the input data. However, due to its nature as a surface-runoff modelling system, longer than daily time steps are inappropriate, since some of the surface processes such as infiltration, retention and evapotranspiration would not be accounted properly. Therefore PRMS expects daily inputs of precipitation, min/max temperatures, Class A pan evaporation etc. We maintained this sensible time interval (from the perspective of surface runoff), despite the emphasis on groundwater in this work. Monthly volumes of pumped or recharged water and boundary inflows were transformed to constant values for each day of a month, i.e., they were distributed evenly in daily time steps. We shall see that this smoothing of the data impacts model response.

PRMS uses a fairly large number of parameters. Some of these were known or could be estimated from readily observable physical quantities such as those related to topography or land use (area, slope, elevation, vegetation etc.). Other parameters could be estimated from bibliographic references. Most parameters concerning the subsurface (soil, shallow and deep reservoirs, Table 1) were left to be determined through the optimisation methods in MMS. For some of these parameters initial values were assigned based on physical estimates, while for others we followed the suggestions of the user's manual.

Model output was compared to groundwater level measurements. As these were taken at monthly intervals, they were considered to represent mean monthly values. Examination of

the groundwater level data, over the main Akrotiri aquifer for the period 1987-2000, revealed that levels from pumped wells were systematically about 1m below corresponding levels from observation wells; the overall, declining trend was otherwise almost identical. A plausible explanation for the discrepancy is that levels in pumped wells were measured 24 hours after the pumps were shutoff, a period insufficient for complete head recovery. For this reason hydraulic head records from pumping wells were disregarded in calibration. Of the remaining boreholes, we kept only those with an uninterrupted record in the period 1989-1999, obtaining an approximate density of ~ 1 observation point/km². The mean level in the ground-water reservoir was determined as the average of these measurements.

4.3 Model Use: Simulation - Optimisation

4.3.1 On the MMS Optimisation Facilities

Having defined the mean groundwater level in the main Akrotiri aquifer as calibration indicator, we employed the facilities of MMS to optimise the parameters of the modules for the subsurface processes (soil, shallow and deep reservoirs). The MMS optimisation minimises the root mean squared error (*rmse*) of the simulated water levels relative to the observed ones (min *rmse* is the objective function). We note in this context that MMS can optimise up to 10 parameters simultaneously. Since in our study we used between 10 and 20 parameters, these were optimised in two steps, in cyclical iteration; one step concerned the group of the shallow subsurface (soil), the other those related to the deep subsurface and to the aquifer. The respective parameters are *soil2gw_max*, *ssr** and *gw** in Table 1 (* as in computer notation sense); the equations in which they operate are shown in Fig. 3.

MMS offers the Rosenbrock (1960) and the Hyper Tunnel (*Restrepo-Posada and Bras, 1982; Bras and Rodríguez-Iturbe, 1985*) methods for optimisation. We examined both. The Rosenbrock method is efficient, but its implementation in MMS is susceptible to local minimum traps, converging rapidly to inferior solutions. We chose the Hyper Tunnel method for its ability to escape from such traps, by searching along several directions in

the parameter space. The Hyper Tunnel method was adapted from the Davidon-Fletcher-Powell method of non-linear optimisation to enable it to handle upper- and lower-bound constraints on parameter values. Furthermore, it was modified by adaptively selecting a subset of parameters that would provide an accelerated path to the optimum value, thus eliminating time-consuming calculations of gradients and the Hessian matrix in some of the iterations. This set of upper- and lower-constrained parameters behaves as a hyper-tunnel in the n -dimensional space, hence the name of the method. Hyper Tunnel is no longer state-of-the-art, predating e.g. the shuffled complex evolution algorithm (e.g. *Gupta et al.*, 1999; *Madsen et al.*, 2003), but its present use is incidental and based simply on the fact that it is one of the two methods available under MMS. Our emphasis is on the procedure for ultimately arriving at an aquifer recharge estimate in a watershed without permanent streams, by calibrating a rainfall-runoff model in the absence of surface runoff information.

4.3.1 Preliminary Study of Model Behaviour

Prior to the optimisation, we explored system behaviour and potential anomalies with two simulations. Parameters were first set at their default values, or inside the recommended ranges, as shown in Table 2 (2nd column); then, the porosity was modified from its default value $n = 0.36$ to the value obtained from pumping tests $n = 0.14$. By the formal measure of *rmse*, $n = 0.14$ improved the simulation performance markedly, reducing *rmse* (over 10 years) from 0.50 m to 0.42 m. However behaviour was notably unphysical, as the aquifer drained completely in nine of ten hydrologic years (indicated by flat lower hydrograph limbs). Clearly, then, the porosity is an important parameter, but it alone cannot ensure physically reasonable model behaviour.

We then tested the ability of MMS to optimise without intervention and obtain physically plausible results via a brief, trial optimisation for 1989-1990. The initial parameters were set in the default ranges, except for $n = 0.14$. After four optimisation cycles the parameters

attained the values in the third column of Table 2, showing hardly any tendency for change and yielding $rmse \approx 0.26$ m. An experienced user would notice the excessive value $soil2_gwmax \approx 7.1$ m/day (≈ 280 in/day, in model-internal use), resulting mainly from a large $gwflow_coef$ that causes the aquifer to dry-up. Indeed, over a ten-year simulation, the aquifer emptied in six years. We therefore decided to steer the initialisation heuristically, based on knowledge of the system characteristics and on information from the initial runs and other simulations.

We performed a series of tests to reduce model parameterisation. The benefit from using a non-linear subsurface reservoir was assessed first. As results differed hardly, we selected the parsimonious linear model, setting $ssr2gw_exp = 1$, $ssrcoef_sq = 0$ and $ssr2gw_max = 1$ (Fig. 3). Then, test runs showed results to be rather insensitive to $ssstor_init$, estimated at 0.25 cm (0.1 in); data of Edmunds and Walton (1980) on soil moisture ~ 5 mg/100g, unsaturated zone thickness ~ 30 m and soil bulk density 1500 kg/m³, yield ~ 2.25 kg/m², or 0.225 cm. Data being insufficient to warrant differentiation of HRUs 6-8, these were grouped in a single HRU. Furthermore, after testing the sensitivity of the results to the impact of the small HRU3 (1.14 km²), we fixed its $soil2_gwmax$ parameter at a low (greenhouses) estimated value. The same was done for HRU9, the small Livadi wetland, which is underlain by rather dense material. Finally, to be able to model any leakage, we also activated the PRMS option of a groundwater sink (parameter $gwres_sink$). The parameters for optimisation were thus reduced from initially 20 to 12.

4.3.2 Initialisation of Parameters

We focused attention on small groups of parameters, starting with the $soil2_gwmax$ values and the porosity and keeping in mind that initial storage and datum should be such that the aquifer would not run dry. The set of initial heuristic parameters is listed in the fourth column of Table 2. Initial $soil2_gwmax$ values for the artificial recharge HRUs were set

based on observations of WDD personnel: ~ 1.25 m (~ 50 in) for HRU5, which receives the bulk of recharge, and one half of that value for HRUs 6-8. The remaining *soil2_gwmax* values were initialised based on our estimates for the irrigated areas (HRU4 should have a higher value than HRU3), on our calculations for the fictitious HRU10 and on the default range for the main aquifer (HRU11). The parameter assignments for the groundwater reservoir were as follows. To increase capacity, the porosity was raised to $n = 0.18$; the datum z and the initial storage x were chosen to satisfy the relation $x/n = y + z$ shown in Fig. 4, using the observation for the mean aquifer level $y \approx 0.6$ m above MSL. Then, two trial runs led to $gwflow_coef = 0.0025 \text{ day}^{-1}$, which did not dry the aquifer. Finally, the sink coefficient was set at 10^{-4} day^{-1} and the subsurface reservoir parameters at their default values. This heuristic initial set gave a physically plausible simulation, in that the aquifer did not empty in any of the ten years.

4.3.3 Parameter Optimisation: Framework and Results

The optimised model was expected to achieve a) small deviations (low *rmse*) of computed from observed groundwater levels, b) good reproduction of the historical *trend* of aquifer levels and c) physically reasonable system behaviour. Use of multiple optimality measures (efficiency criteria) is good practise in hydrologic modelling. For example, WMO (1986) has used the coefficient of determination (R^2 , e.g. *Nash and Sutcliffe, 1970*) and the relative volume error, which *Lindström (1997)* combined into a single weighted efficiency criterion. Use of two or more optimality criteria is also akin to the multi-objective optimisation for multiple flux output models (*Gupta et al., 1998*) and for hydrologic models (*Madsen, 2000*). The record includes periods of high (1989-1990) and of essentially no artificial recharge (1998-1999), as well as of average recharge (e.g. 1994-1995). To ensure adequate model behaviour under such variable conditions, parameters were calibrated on 1989-1990, 1994-1995 and 1998-1999 data, reserving the remaining 7 years for validation (split-sample).

Initially, parameters were optimised in two groups, in cyclical iteration; with convergence progress, the set could be reduced to 10 parameters and optimised in one pass, at the end re-checking the influence of those two parameters on the optimised set. Admittedly, this approach can increase the probability of reaching a sub-optimal solution. Depending on conditions, convergence was achieved in two to four complete two-step cycles, with 10-80 iterations per cycle; the higher iterations number applies early in the process of a difficult calibration case and the lower one to the last cycle of an easier calibration case.

The data series 1989-1990, 1994-1995 and 1998-1999 gave different sets of optimal parameters [see also *Gupta et al. (1998)*], which indicates deficient model structure. Such a characteristic is expected, to some degree, of all models, but more of conceptual ones. The optimal parameters are shown in Table 2, columns 5-7 and the associated *rmse* values indicate good calibration. The three sets were melded into the optimal parameter set listed in column 8 of Table 2, by weighing their values according to the relative duration of the corresponding conditions in 1989-1999, namely 0.15, 0.7 and 0.15. The optimised watershed model was verified for 1990-1994 (*rmse* = 0.33 m) and 1995-1998 (*rmse* = 0.28 m).

Simulation of the Akrotiri basin behaviour with the thus optimised parameters (validation) has reasonable features. Evidently, from Fig. 7, the aquifer does not empty (lower hydrograph limbs are not flat). In addition to the relatively low *rmse* values, reproduction of the linear trend of the measured mean aquifer level fluctuation is excellent in 1990-1994 and acceptable in 1995-1998. Table 3 gives the details of the hydrologic balance for the Akrotiri basin and for the part overlying the main aquifer, as computed from the simulations with optimal parameters.

5. Discussion and Assessment of Results

Calibration of PRMS for the Akrotiri basin based on aquifer level data was achieved by the Hyper Tunnel method of parameter optimisation via a manual-heuristic intervention.

The purely automatic optimisation of PRMS with MMS did not ensure a good outcome. Generally, one cannot know whether the located optimum is indeed the global one, despite that method's facility to search for the global optimum in several directions in the parameter space. Local minima arise when the objective function is non-convex, non-convexity being caused by non-linearity of physics (*Gordon et al.*, 2000). Thus, since the optimisation was guided manually, a different initialisation would have likely given a different final set. Nevertheless, in practice, it is usually sufficient to find a parameter set that gives low error measures and reasonable physical behaviour.

First, the model structure was reduced to its most essential elements. For initialisation, information about the system characteristics was used and model response sensitivity to parameters was tested. The impact of certain parameters was assessed beforehand. For example, despite the large *soil2gw_max* values of HRUs 5-8, their contribution to the hydrologic balance is moderated by their small size ($A_{\text{total}} = 45$ ha); influence exert also the large units HRU11 (~ 22 km²) and HRU4. Datum, porosity, initial storage, and flow coefficient of the main aquifer reservoir were important parameters that were initialised judiciously. In the Akrotiri basin study, the linear reservoir model for the unsaturated zone afforded equal modelling efficiency as the more complex non-linear model, while employing a groundwater sink improved the hydrologic balance.

A sensitivity study, made with the MMS-internal facility (*Leavesley et al.*, 1983), showed the parameter group of the main aquifer reservoir as dominant, specifically *gw_porosity*, *gw_depth_datum* and *gwflow_coef*. Second in importance are the soil zone parameters *ssr2gw_rate* and *ssrcoef_lin* and the parameter *gwsink_coef*, in that order. Third is the group of *soil2gw_max* parameters of the artificial recharge units HRU5-8, the main aquifer HRU11 and the agricultural HRU4, their relative importance varying depending on a year's artificial recharge intensity relative to irrigation and natural recharge rates.

The model was verified with data that were not used for its calibration. It is noteworthy that the computed evolution of the mean groundwater level for the periods 1990-1994 and 1995-1998, shown in Fig. 7, varies, generally, more smoothly than the measured one. This response was anticipated (see section 4.2) and can be partially attributed to the fact that the volumes of pumped and recharged water and the aquifer boundary inflows were artificially distributed evenly over a month. Figure 7 shows also that the linear trend of the mean aquifer water table evolution was reproduced quite well. While the modelled regression lines are flatter than the ones derived from the observations (mainly 1995-1998), the modelled curve divides correctly the record in a period of increasing and a period of declining aquifer level, approximately corresponding to the periods of higher (earlier) and of lower recharge (later).

Finally, the model estimated the mean annual value of natural recharge at ~ 49 mm, a value compatible with the estimates by *Edmunds et al.* (1988) for the period 1977-1980, from chloride analysis ~ 61 mm and from tritium analysis ~ 53 mm.

6. Conclusions

The goals of the work were mission-oriented and applied research in nature. The former concerned estimation of the Akrotiri aquifer's natural recharge, for use in the *WASSER* project (*Koussis*, ed., 2000; *Koussis et al.*, 2002) to assess management options for that basin's and underlying aquifer's stressed water resources. Natural recharge was estimated by modelling the basin's hydrologic balance. The applied research objectives were: a) to develop a hydrologic model calibration methodology that is based on groundwater data and b) to assess the capability provided by PRMS/MMS for automatic parameter calibration.

The necessity for the groundwater-based model calibration methodology arose from the lack of surface runoff observations in the Akrotiri basin. This circumstance is often met in the ephemeral surface runoff in semiarid or arid regions, but is also frequently encountered

in other regions due to lack of streamflow measurements. This task was accomplished by enhancing the PRMS code, in order to: a) calculate water level changes in the aquifer in response to artificial recharge and to pumping, b) convert aquifer water volumes per unit area to groundwater columns, through division by the aquifer porosity and c) position those columns relative to a datum. The observable groundwater level became thus the operative calibration indicator. The limitation imposed by the lack of communication among groundwater reservoirs in PRMS was overcome by introducing a fictitious HRU that established a one-way connection to hydrologic units supplying the main Akrotiri aquifer.

The modelling of the Akrotiri basin and aquifer leads us to conclude that automatic calibration of the distributed hydrologic model PRMS within MMS cannot ensure a good outcome. It is therefore not a tool for novices. On the other hand, automatic optimisation of PRMS with MMS combined with heuristic intervention by experts is a valuable facility that can save time and improve modelling performance. To this end, optimisation results must be scrutinised carefully, melding the viewpoint of physical sense with mathematical efficiency criteria, since the inverse problem is not well posed and its solution not unique.

In the Akrotiri modelling study, to guide the optimisation rapidly to a reasonable set of parameters, we had to use available knowledge about the system characteristics and to make simulations, testing system response (sensitivity) to parameter values. Once seeded with sound parameter estimates (not arbitrary or default values), the Hyper Tunnel method of optimisation worked quite reliably, showing good ability to escape from local minima by searching along several directions in the parameter space.

The PRMS option of using a linear, instead of a non-linear, reservoir model for the unsaturated zone proved to be parsimonious in the Akrotiri case; it afforded equal modelling efficiency at a lower complexity. The groundwater sink option proved effective in this study, especially in achieving a good hydrologic balance. Accomplishment of the applied

research objectives (groundwater-based calibration and objective optimisation of the PRMS/MMS parameters) also ensured attainment of the mission-oriented goal of recharge estimation, obtained from the calibrated model of the hydrologic balance of the Akrotiri basin and underlying aquifer. In the validation tests, the PRMS model achieved a low simulation error, reasonable match of the aquifer level evolution and physical behaviour (the aquifer reservoir did not empty); it can therefore be a useful tool for evaluating management scenarios of that basin's stressed water resources.

Acknowledgements

The first three authors acknowledge with gratitude the support of Directorate-General *Research* of the European Commission, under Contract Nr. ENV4-CT97-0459 (project *WASSER*) and of the General Secretariat for Research and Technology, Hellenic Ministry for Development. The authors also appreciate the contribution of data and information by Adonis Georgiou and Christos Ioannou, hydrogeologists with the Water Development Department, Ministry of Agriculture, Natural Resources and Environment of Cyprus.

References

- Adams III, P. E., 2002. Data and modeling: The future of water resources planning and management, *Journal of Water Resources Planning and Management*, ASCE, (1) 1-2.
- Boyle, D. P., Gupta, H. V. and Sorooshian, S., 2000. Toward improved calibration of hydrologic models: Combining the strengths of manual and automatic methods. *Water Resour. Res.* 36 (12), pp. 3663 – 3674.
- Bras, R. and Restrepo-Posada, P.J., 1980. Real Time Parameter Estimation in Stochastic Conceptual Rainfall-Runoff Models. *Proc. Third International Congress on Stochastic Hydraulics*, Tokyo.
- Bras, R. and Rodríguez-Iturbe, I., 1985. *Random Functions and Hydrology*, Addison Wesley, pp. 484-489.

- Edmunds, W.M. and Walton, N.R.G., 1980. A geochemical and isotopic approach to recharge evaluation in semi-arid zones – past and present, in *Arid Zone Hydrology: Investigations with Isotope Techniques*, IAEA, Vienna, pp. 47-68.
- Edmunds, W.M., Darling, W.G. and Kinniburgh, D.G., 1988. Solute profile techniques for recharge estimation in semi-arid and arid terrain, in *Estimation of Natural Groundwater Recharge*, I. Simmers (Ed.), Reidel Publishing Co., pp. 139-157.
- Gordon, E., Shamir, U. and Bensbat, J., 2000. Optimal management of a regional aquifer under salinization conditions, *Water Resour. Res.* 36 (11), pp. 3193-3203.
- Greitzer, Y. and C. Constantinou, 1969. Report on the hydrogeology of Kouris river valley area, Tahal Consulting Engineers Ltd., Tel Aviv.
- Gupta, H.S., Soroosian, S. and Yapo, P.O., 1998. Toward improved calibration of hydrologic models: Multiple and noncommensurable measures of information, *Water Resour. Res.* 34 (4), pp. 751 – 763.
- Gupta, H.S., Soroosian, S. and Yapo, P.O., 1999. Status of automatic calibration for hydrologic models: Comparison with multilevel expert calibration, *J. Hydrol. Eng.*, 4 (2), pp. 135 – 143.
- Hill, M. C., 1992. A computer program (MODFLOWP) for estimating parameters of a transient, three-dimensional, ground-water flow model using nonlinear regression, U.S. Geological Survey, Open File Report 91-484, pp. 3-4 and 15.
- International Association of Hydrological Sciences (IAHS), 2002. IAHS Decade on Prediction in Ungauged Basins (PUB), <http://www.cig.ensmp.fr/%7Eiahs/PUBs/PUB-proposal-250602.htm>.
- Jacovides, J., 1982. Southern conveyor project, Feasibility study: Groundwater resources, Volume 3, Water Development Department, Nicosia, Republic of Cyprus.

- Koussis, A.D. (ed.), 2001. WASSER: Utilisation of Groundwater Desalination and Wastewater Reuse in the Water Supply of Seasonally-Stressed Regions, Final Project Report, with Appendices, National Observatory of Athens, Athens, Greece.
- Koussis, A.D., A. Kotronarou, G. Destouni & C. Prieto, 2002. Intensive groundwater development in coastal zones and small islands, Chapter 6 in Intensive Use of Groundwater: Challenges and Opportunities, R. Llamas and E. Custodio (eds), Balkema.
- Leavesley, G. H. and Stannard, L. G., 1995. The precipitation – runoff modeling system – PRMS, Chapter 9 in Computer models of watershed hydrology, V. P. Singh (ed.), Water Resources Publications.
- Leavesley G. H., Lichty, R. W., Troutman, B. M. and Saldon, L.G., 1983. Precipitation – runoff modeling system: User’s manual, Water-Resources Investigations 83 – 4238, Denver, Colorado.
- Leavesley G. H., Restrepo, P. J., Markstrom, S. L., Dixon, M. and Stannard, L. G., 1996. The modular modeling system (MMS): User’s manual. U.S. Geological Survey Open File Report 96 – 151, Denver, Colorado.
- Leavesley, G. H., Markstrom, S. L., Restrepo, P.J. and Viger R.J., 2002. A modular approach to addressing model design, scale and parameter estimation issues in distributed hydrological modelling, *Hydrol. Process.*, 16, 173-187.
- Lindström, G., 1997. A simple automatic calibration routine for the HBV model, *Nordic Hydrology*, 28 (3), pp. 153 – 168.
- Madsen, H., 2000. Automatic calibration of a conceptual rainfall-runoff model using multiple objectives, *J. Hydrol.* 235: 276-288.
- Madsen, H., Wilson, G. and Ammentorp, H. C., 2002. Comparison of different automated strategies for calibration of rainfall-runoff models, *J. Hydrol.* 261: 48-59.

- Madsen, H., 2003. Parameter estimation in distributed hydrological catchment modelling using automatic calibration with multiple objectives, *Advances in Water Resources* 26: 205-216.
- Mazi, K., 2000. Optimisation of a model for the hydrologic balance with groundwater data. Graduate thesis (in Greek), National Technical University of Athens.
- Nash, J. E. and Sutcliffe, J. V., 1970. Riverflow forecasting through conceptual models, Part I: A discussion of principles, *J. Hydrol.* Vol. 10, pp. 282 – 290.
- Refsgaard, J. C., 1997. Parametrisation, calibration and validation of distributed hydrological models, *J. Hydrol.* 198: 69-97.
- Refsgaard, J. C. and Knudsen, J., 1996. Operational validation and intercomparison of different types of hydrological models, *Water Resour. Res.* 32 (7), pp. 2189 – 2202.
- Restrepo-Posada, P. J. and Bras, R. L., 1982. Automatic parameter estimation of a large conceptual rainfall-runoff model: A maximum likelihood approach. Ralph M. Parsons Laboratory for Water Resources and Hydrodynamics, M.I.T., Technical Report 267.
- Rosenbrock H. H., 1960. An automatic method of finding the greatest or least value of a function, *Computer Journal*, 3, pp. 175 – 184.
- Sorooshian S. and Gupta V. K., 1995. Model calibration, Chapter 2 in *Computer models of watershed hydrology*, V. P. Singh (ed.), Water Resources Publications.
- Viger, R. J., Markstrom, S.L., and Leavesley, G.H., 2001. The GIS Weasel - An Interface for the Treatment of Spatial Information Used in Watershed Modeling and Water Resource Management, Proc. First Federal Interagency Hydrologic Modeling Conference, April 19-23, 1998, Las Vegas, Nevada, Vol. II, Chapter 7, pp. 73-80.
- WMO, 1986. Intercomparison of models of snowmelt runoff, *Operational Hydrology Report No. 23*, Geneva Switzerland.
- Yapo, P.A., Gupta, H. V. and Sorooshian, S., 1998. Multi-objective global optimization for hydrologic models, *J. Hydrol.* 204: 83-97.

Figure Captions

Figure 1 – Akrotiri hydrologic basin, aquifer and HRUs.

Figure 2 – Schematic of the PRMS model.

Figure 3 – Model components and equations for the sub-surface simulation in PRMS.

Figure 4 – Schematic representation of the “datum” parameter: $x/n = y+z$, where x = water column in groundwater reservoir, n = porosity, y = water level above MSL and z = elevation of MSL relative to the datum.

Figure 5 – Location of North-South transect A – A’ (left) and generalised geological cross section A – A’ of the Akrotiri aquifer (right), adapted from Greitzer and Constantinou (1969).

Figure 6 – Schematic of the links of the HRUs with the soil, subsurface and groundwater reservoirs in PRMS.

HRU: Hydrologic Response Unit; SZR: Soil Zone Reservoir; SSR: Subsurface Reservoir; GWR: Groundwater Reservoir. The numbers correspond to the numbering of the HRUs and to their interconnections with their associated reservoirs; the arrows indicate system functioning in PRMS. For example: HRU1, SZR1: HRU with impermeable soil and SZR1, the associated soil zone reservoir; HRU2, SZR2: HRU with thin aquifer and SZR2, the associated soil zone reservoir; SSR1: Subsurface reservoir associated with HRU1 and HRU2; GWR1: Groundwater reservoir associated with SSR1.

Figure 7 – Evolution of mean groundwater (gw) level of Akrotiri aquifer; observed groundwater level (thin continuous line), simulated groundwater level (heavy line) and their linear trends in the verification periods 1990-1994 and 1995-1998 (MSL: mean sea level).





List of Tables

Table 1. Range and default values of parameters

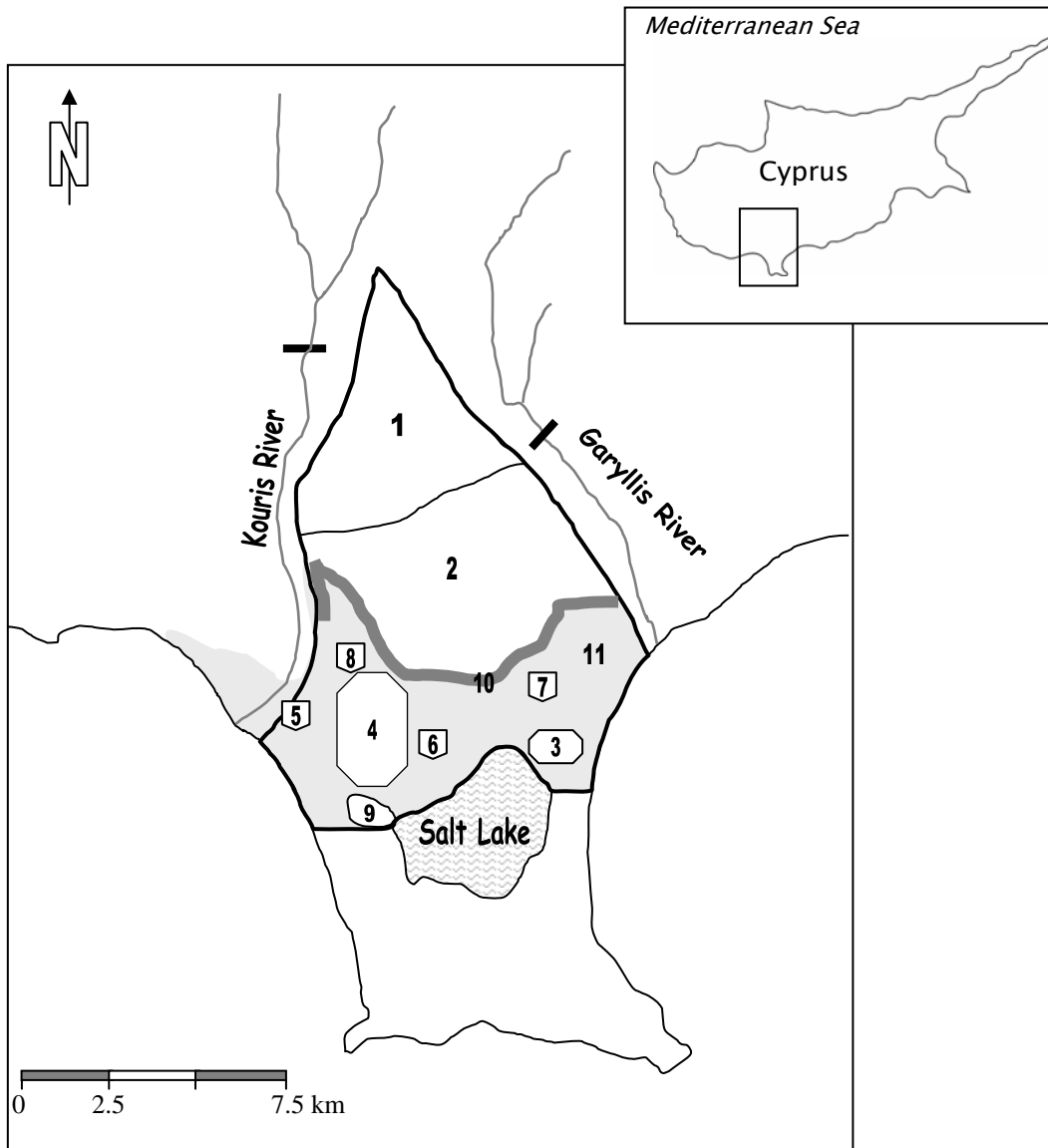
Table 2. Initial and optimised parameter values

Table 3. Water balance in the aquifer and in the basin (in mm)



-  Boundary of Akrotiri Study Area
-  Akrotiri Aquifer
-  Location of dam
-  3 HRU, not to scale

INPUTS

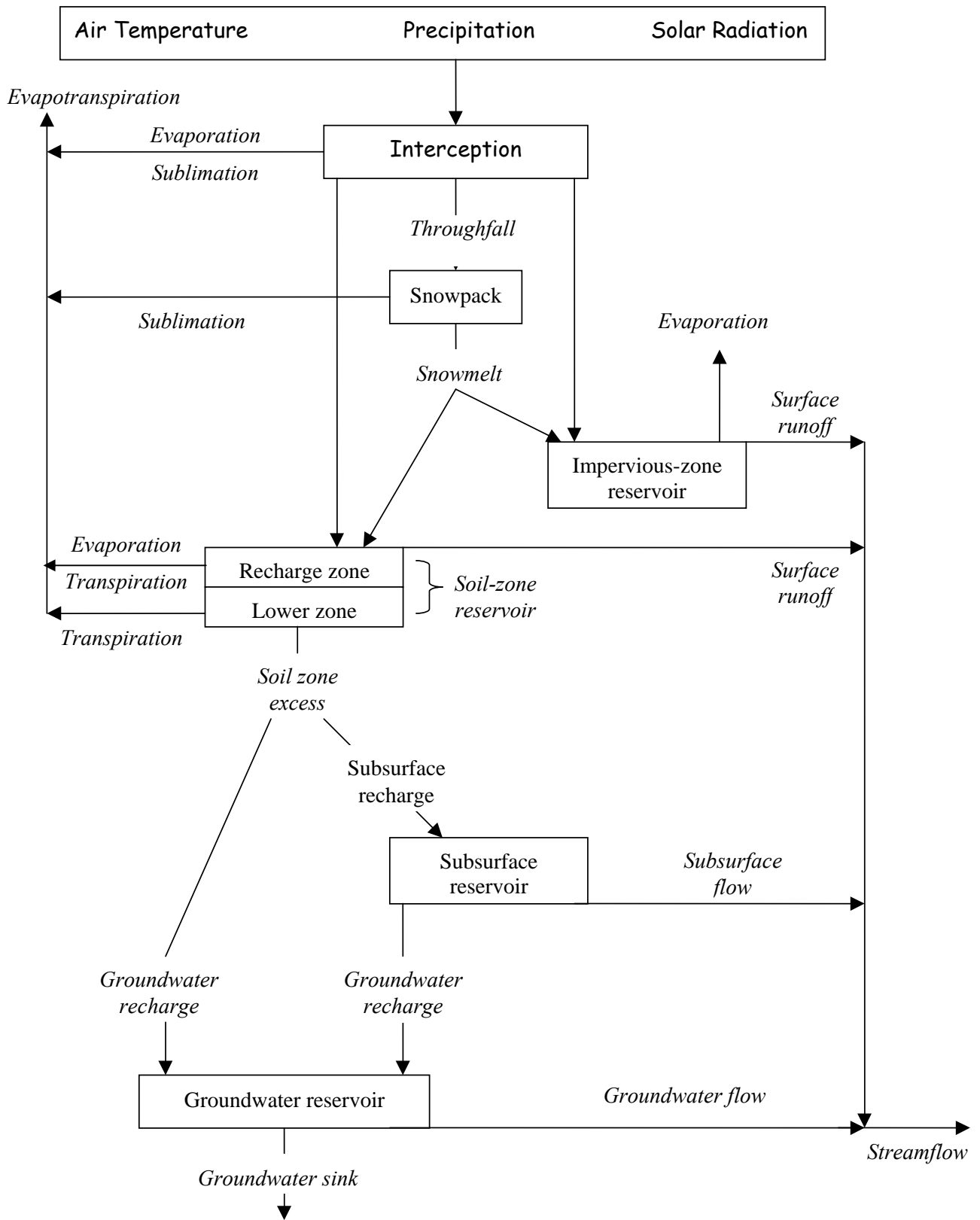

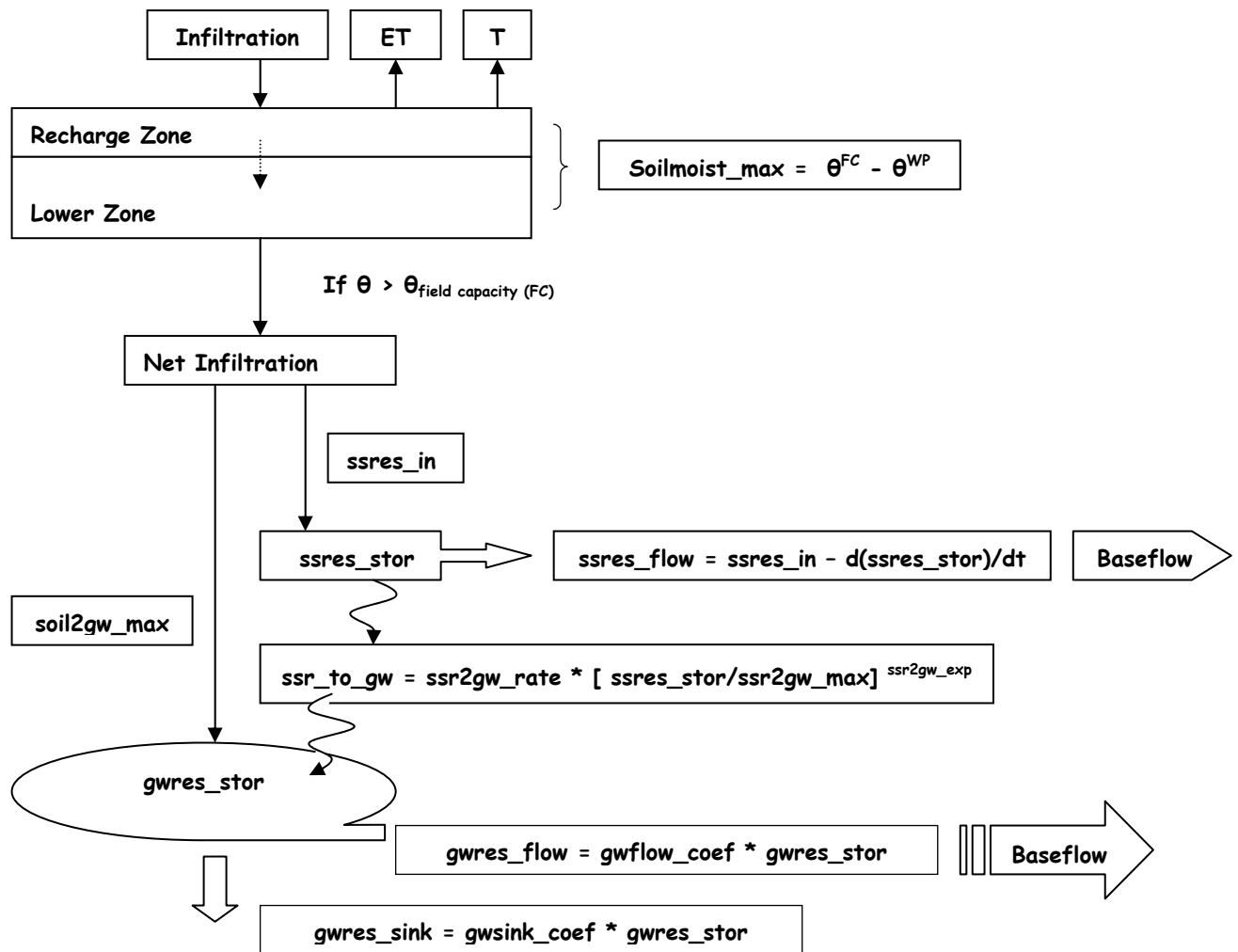

ET: evapotranspiration

T: transpiration

soilmoist_max: maximum available water holding capacity of soil profile [inches]. Soil profile is from the surface to the bottom of rooting zone

θ^{FC} , θ^{WP} : water content at field capacity and water content at wilting point, respectively

ssres_in: total inflow to each subsurface reservoir [inches]

ssres_stor: storage in each subsurface reservoir

ssres_flow: contribution to streamflow from each subsurface reservoir [inches]

soil2gw_max: the amount of the soil water excess for an HRU that is routed directly to the associated groundwater reservoir each day [inches]

ssres_stor: storage in each subsurface reservoir [inches]

ssr_to_gw: flow from each subsurface reservoir to its associated groundwater reservoir

ssr2gw_rate: coefficient to route water from subsurface to groundwater

ssr2gw_max: maximum value for water routed from subsurface to groundwater

ssr2gw_exp: coefficient to route water from subsurface to groundwater

gwres_stor: total storage in each groundwater reservoir

gwres_flow: contribution to streamflow from each groundwater reservoir

gwflow_coef: coefficient to obtain groundwater flow contribution to streamflow

gwres_sink: flow routed to a groundwater sink

gwsink_coef: coefficient to compute seepage from each reservoir to a groundwater sink

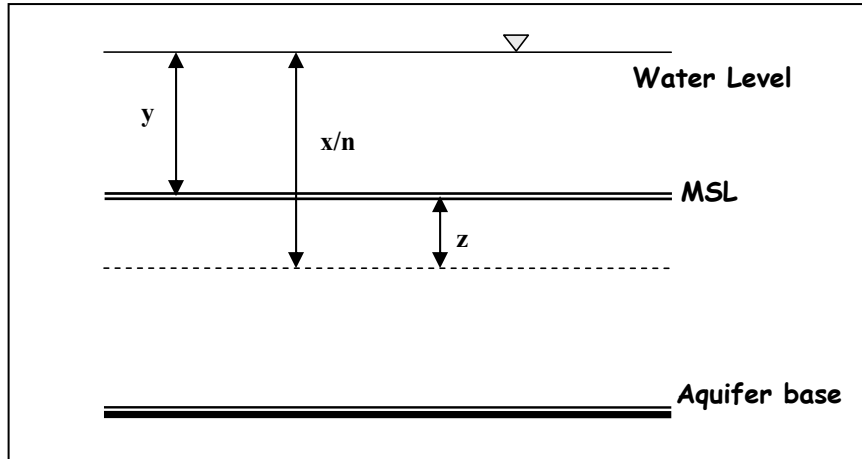

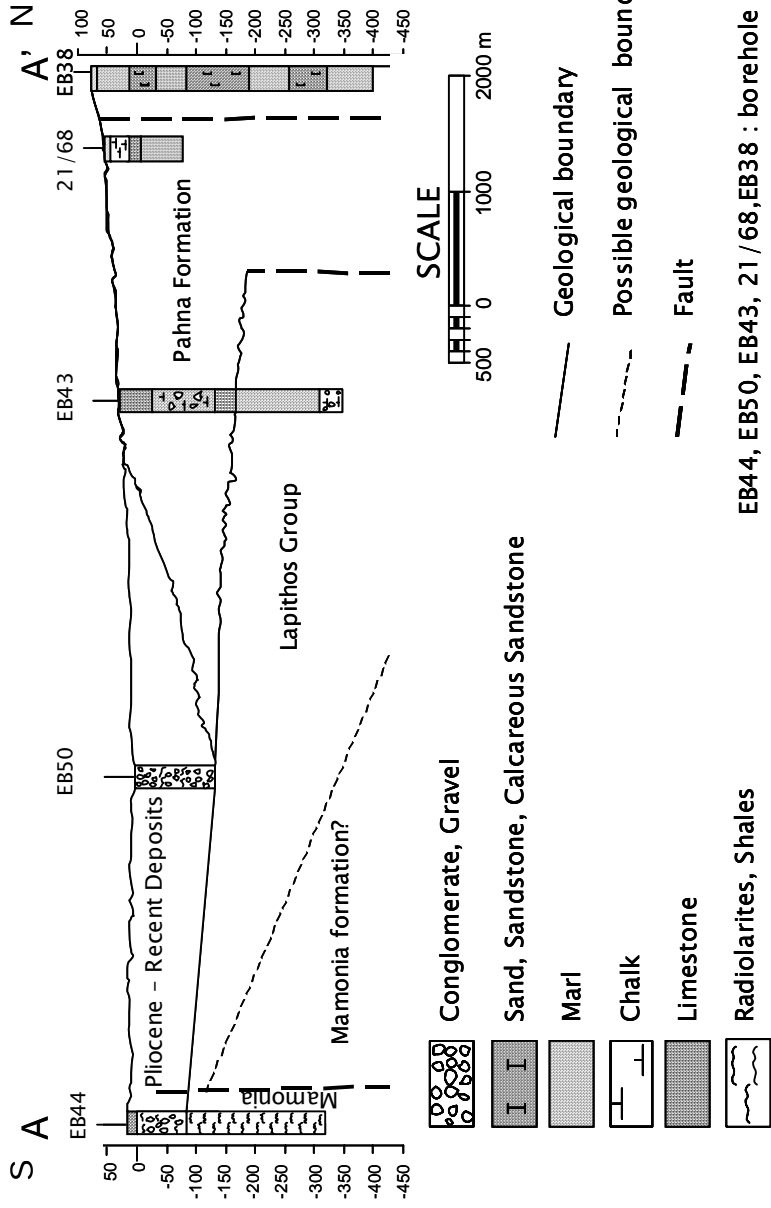
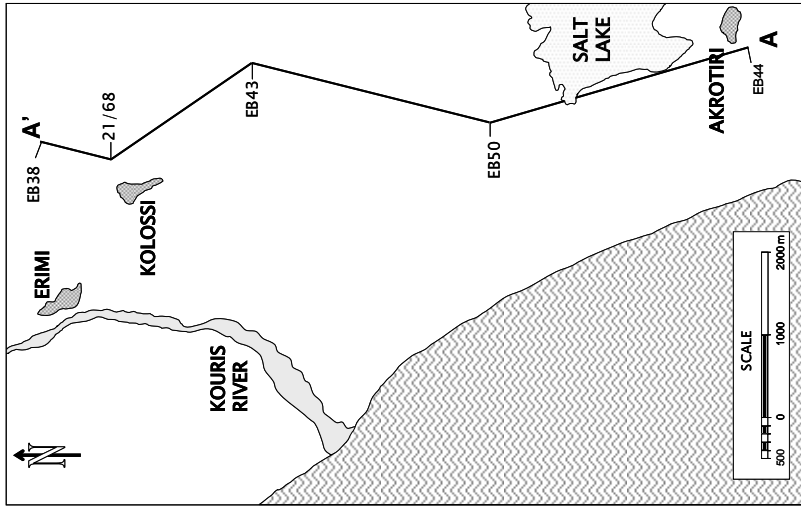

EB44, EB50, EB43, 21/68, EB38 : borehole records

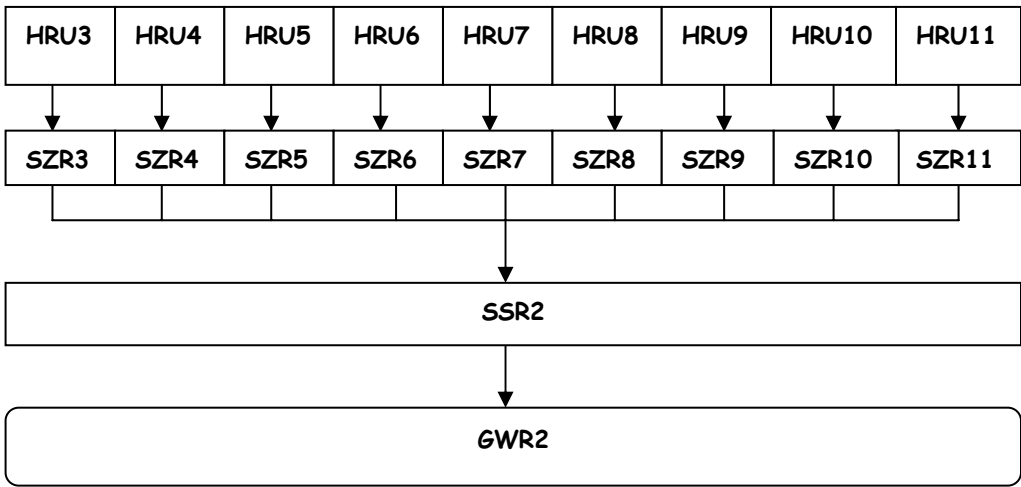
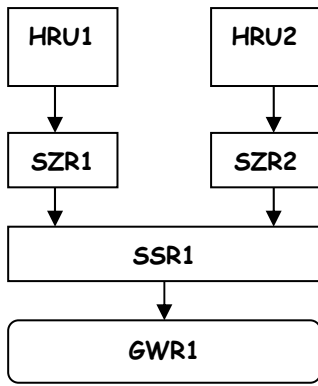

Hydrologic Years 1990 – 1994 and 1995–1998

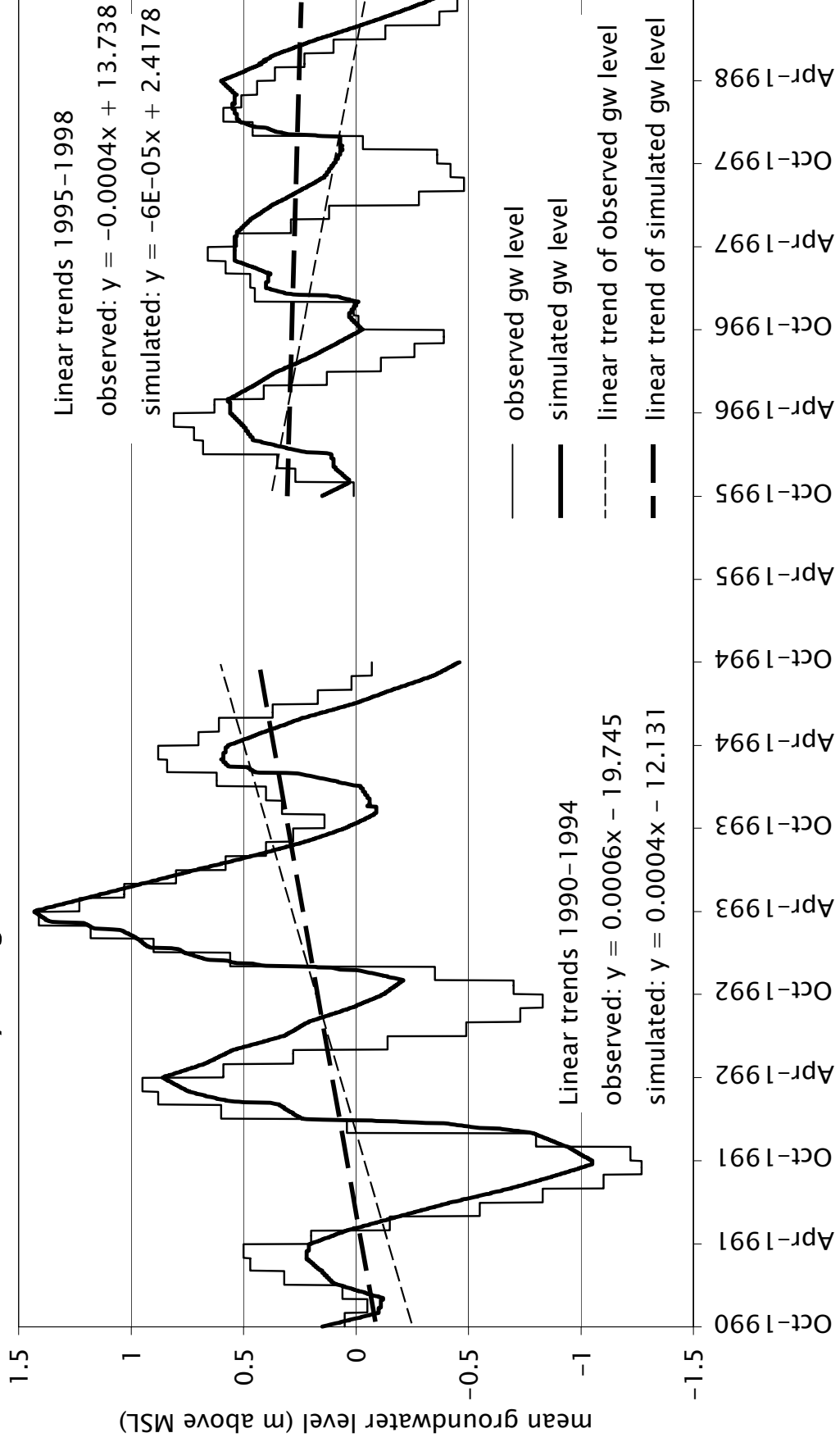

Table 1. Range and default values of parameters

Parameter	Declaration (Units)	Default value	Range
soil2gw_max	Soil water excess for an HRU that is routed directly to the associated groundwater reservoir each day (inches)	0 (depends on HRU)	0 - 5
ssr2gw_exp	Coefficient for routing water from subsurface to groundwater (day ⁻¹)	1	0 - 3
ssr2gw_rate	Coefficient for routing water from subsurface to groundwater (day ⁻¹)	0.1	0 - 1
ssrcoef_lin	Routing coefficient of linear sub-surface storage to streamflow (day ⁻¹)	0.1	0 - 1
ssrcoef_sq	Routing coefficient of non-linear subsurface storage to streamflow (day ⁻²)	0.1	0 - 1
ssr2gw_max	Maximum value of water routed from subsurface to groundwater each day (inches)	1	0 - 20
ssstor_init	Initial storage in each subsurface reservoir (inches); estimation based on observed flow (inches)	0	0 - 20
gw_depth_datum	Datum of groundwater reservoir (aquifer) (m)	0	-10 ³ - 10 ³
gw_porosity	Groundwater reservoir porosity (-)	0.36	0 - 1
gwflow_coef	Routing coefficient for obtaining groundwater flow contribution to streamflow (day ⁻¹)	0.015	0 - 1
gwsink_coef	Coefficient for computing the seepage from each groundwater reservoir to a sink (day ⁻¹)	0	0 - 1
gwstor_init	Storage in each groundwater reservoir at beginning of run (inches)	0.1	0 - 20

Table 2. Initial and optimised parameter values

Parameter	Initial	1989-1990 trial optimisation	Heuristic	1989-1990	1994-1995	1998-1999	Composite
soil2gw_max							
HRU3	0.5	5.95	0.1	-----	-----	-----	0.1
HRU4	0.5	0.5	1.0	1.0	1.03	1.0	1.02
HRU5	5	281.0	50.0	146.45	92.78	94.74	101.12
HRU6,7,8	5	22.52	25.0	5.47	25.0	25.0	22.07
HRU9	0.01	0.01	0.1	-----	-----	-----	0.1
HRU10	5	5.0	1.0	1.43	9.18	4.31	7.29
HRU11	0.5	0.85	1.0	1.08	0.15	1.0	0.42
ssr2gw_exp	1.0	-	1.0	-----	-----	-----	1.0
ssr2gw_rate	0.1	0.0	0.1	0.012	0.0297	1.001	0.173
ssrcoef_lin	0.1	4.15	0.1	2.18	0.053	0.053	0.372
ssrcoef_sq	0.0	-	0.0	-----	-----	-----	0.0
ssr2gw_max	1.0	-	1.0	-----	-----	-----	1.0
ssstor_init	0.0	0.12	0.1	-----	-----	-----	0.1
gw_depth_datum	0	0.0	0.75	1.036	0.95	1.507	1.046
gw_porosity	0.36/0.14	0.10	0.18	0.127	0.167	0.178	0.163
gwflow_coef	0.015	0.0117	0.0025	0.002	0.00208	0.002276	0.002097
gwsink_coef	0	-	0.0001	0.000077	0.000232	0.000115	0.000191
gwstor_init	0	0.0016	10.0	8.72	7.27	8.45	7.66
RMS ERROR (m)		0.246		0.104	0.117	0.030	0.332* / 0.280°

* : years 1990-1994; ° : years 1995-1998

Table 3. Water balance in the aquifer and in the basin (in mm)

	Precip	Irrigation	Recharge	Inflows	Σ Inputs	ET	Outflows	Pumping	Sink	ΔStorage	Balance	$\% \Sigma$ Inputs
Aquifer	410.0	216.1	117.5	255.4	999.0	497.6	216.0	266.0	15.2	-10.75	15.0	1.5
Basin	436.0	103.0	56.0	122.0	717.0	359.0	219.0	127.0	6.6	-7.1	12.5	1.7