

Integrated modelling of a River-Reservoir system using OpenMI

E. Safiolea, A. Efstratiadis, S. Kozanis, Y. Liagouris, and C. Papathanasiou

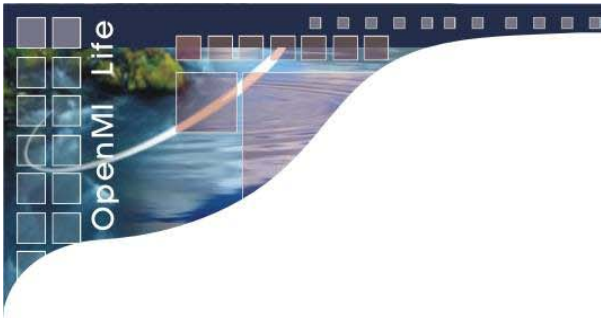

Aim of this Study

- To prove that OpenMI can be successfully used to assess real world problems
- To evaluate whether OpenMI can improve water resources modelling
- To assist Thessaly Competent Authorities in their decision making process by providing them useful tools for their analyses



Why linking a Reservoir Management Model with a R-R model

This case study involves linking a Reservoir Management Model with a Rainfall-Runoff model

- Reservoir studies require reliable runoff data; however, the quantity and quality of historical records (if they exist) are usually inadequate.
- Hydrological models are well-established tools for predicting discharge across a river network, at various time-scales.
- Such models, especially the physically-based ones, are the only rational tools to assess the impacts of future events on runoff regime, such as land-use, vegetation, and climate changes.
- Although some hydrological models include reservoir simulation routines, the emphasis is merely given on the hydraulic processes (i.e. spillway routing) and not on the water management aspects.

Located on the South Part of the Thessaly Water District

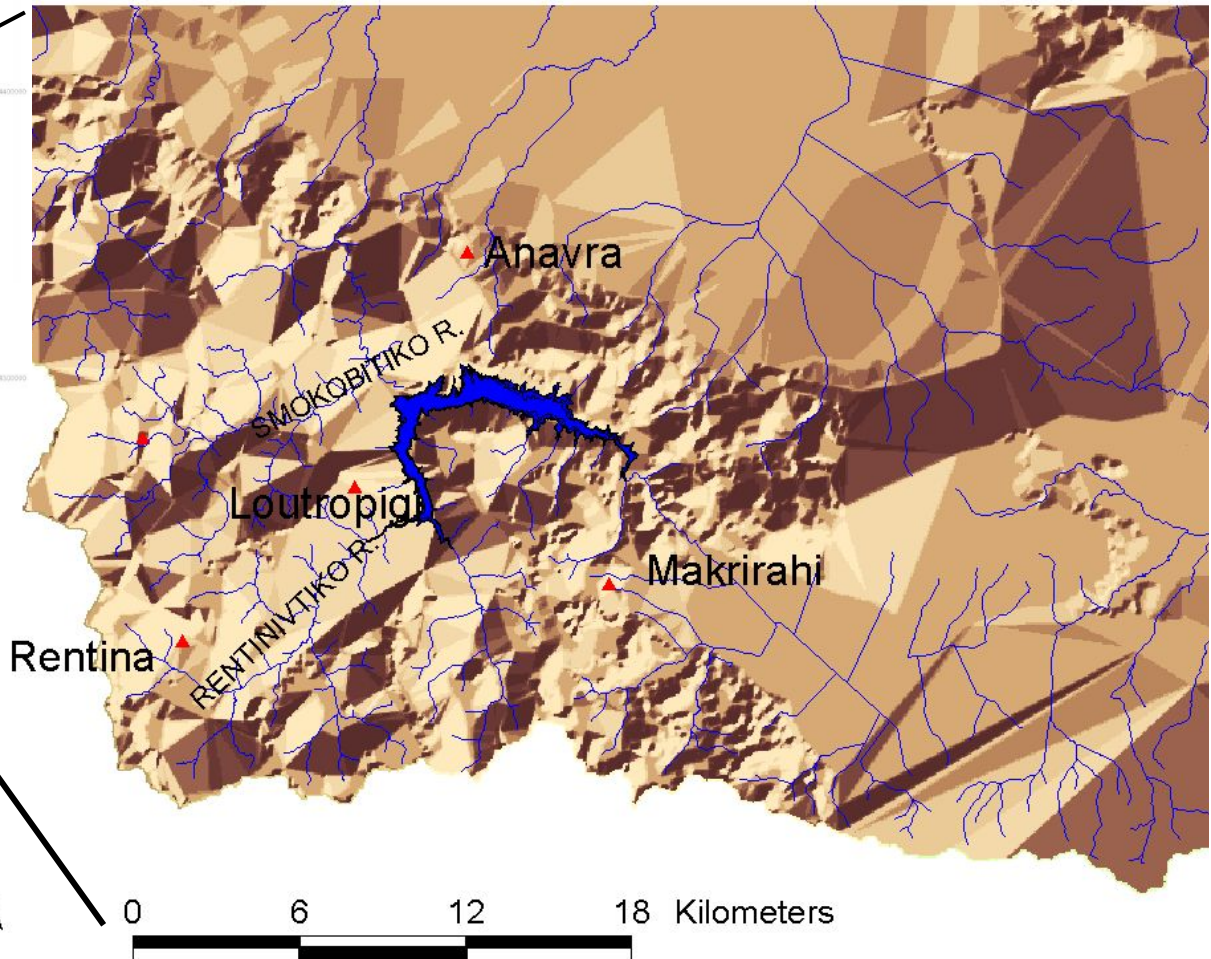
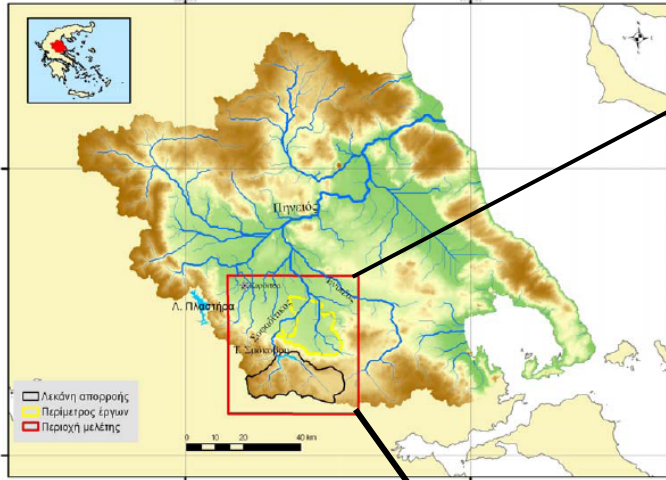

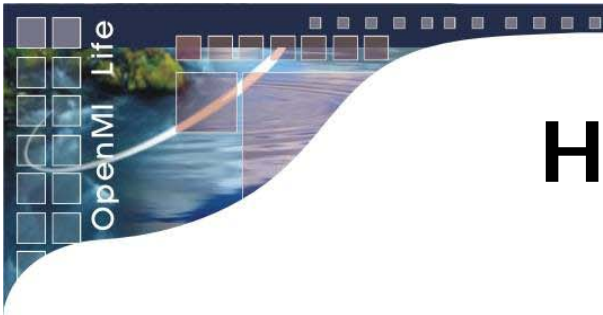

Historical Background



- Newly constructed reservoir (pilot operation July 2002).
- Located on the SW area of Thessaly plain, a major agricultural area of Greece, suffering from severe water deficits during dry years and water table degradation, due to pumping.
- Aims to supply 25 000 ha of agricultural land, through a pressured pipe network, thus limiting the extensive use of boreholes.
- Today, small part of the network, 1800 ha, is finished and other 3700 ha are irrigated through small barrages.
- Moreover, the reservoir will serve for providing drinking water for 55 000 residents and ensuring permanent flow downstream of the dam, during the dry period.

The Smokovo Reservoir Functions

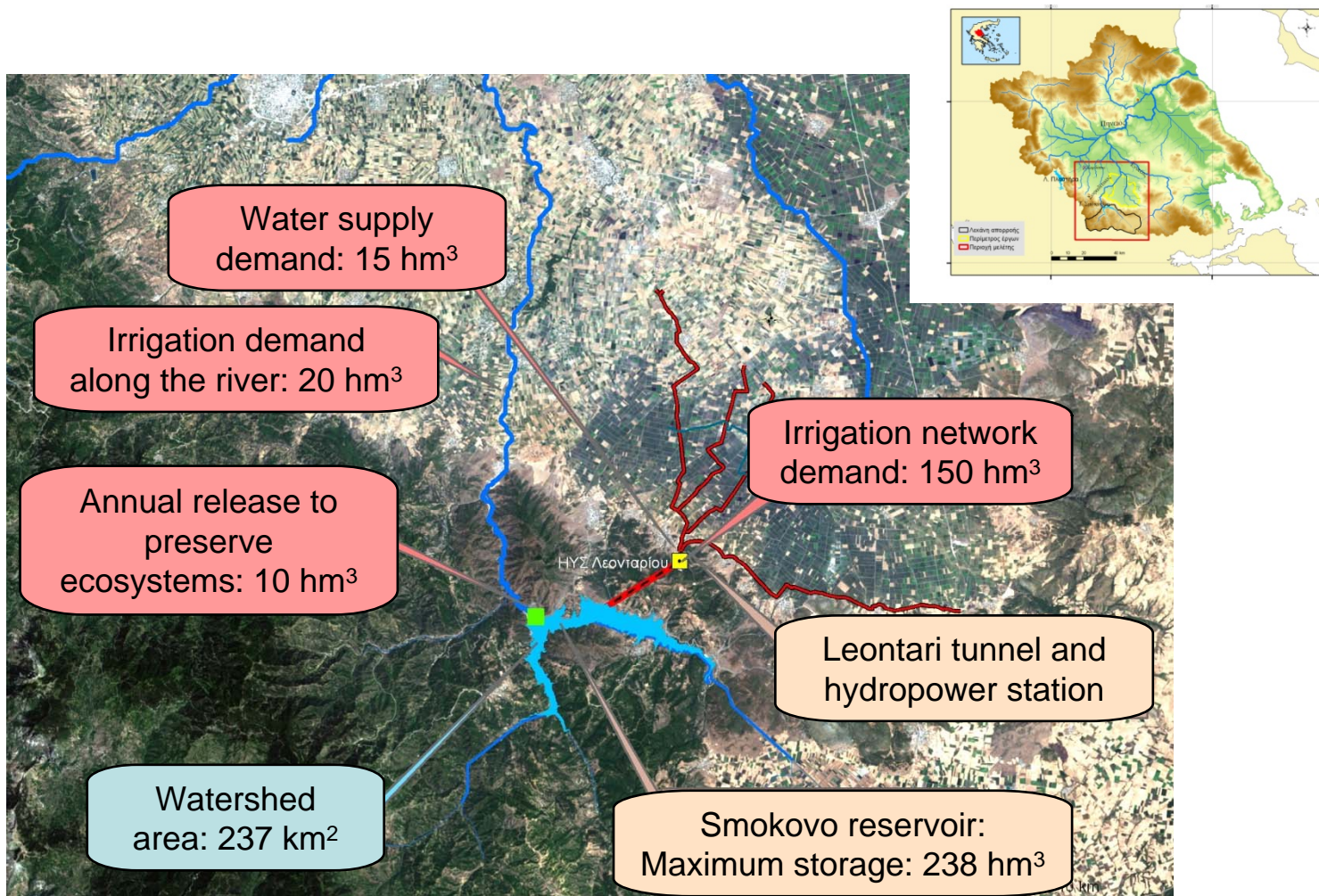

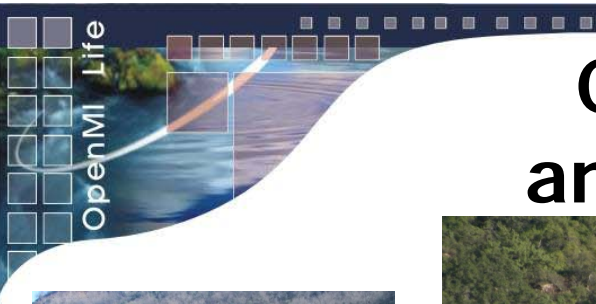

Coexistence of Nature and Hydraulic Structures



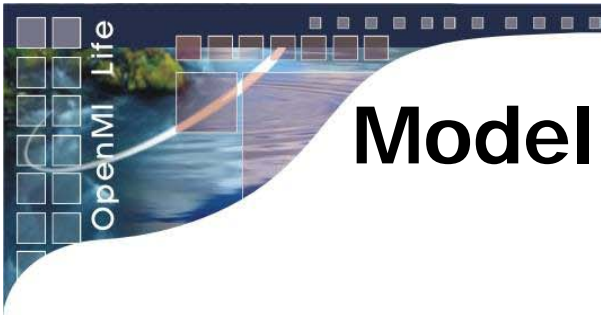

Modelling Issues Related to the Case Study



- Migrate a Reservoir Management Model of general purpose to the OpenMI Environment (engine written in Borland Delphi)
- Incorporate multiple water uses and assign operation rules to each use
- Take into account all essential water balance components, including losses due to evaporation and leakage
- Set up a MIKE-11 model for the upstream Smokovo basin to provide the inflow to the reservoir
- Compare the independent and linked model runs

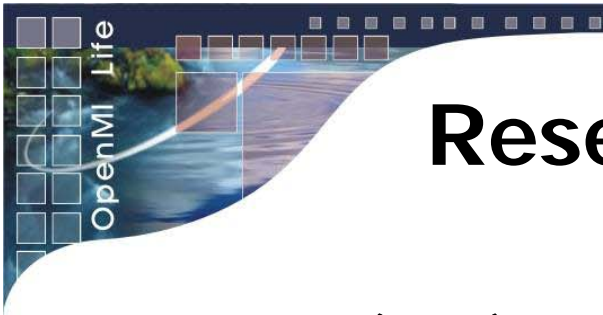

Reservoir Simulation Model: Input Data



- Time step (daily) and time horizon of simulation
- Level-storage and level-surface data (given as point series)
- Characteristic levels (minimum, maximum, initial)
- Upstream watershed area
- Time series of precipitation and evaporation depths
- Leakage function coefficients (monthly)
- Water uses properties (priority order, demand time series, operation rules)

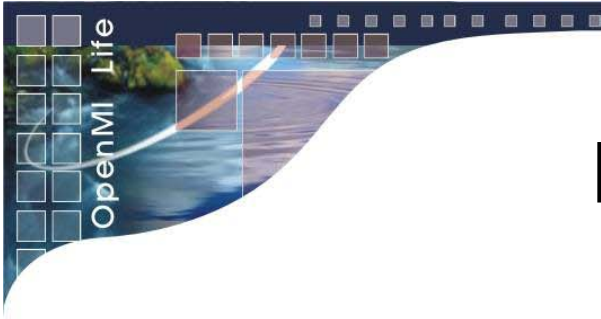

Reservoir Properties

- Minimum level +285 m
- Intake level +331 m
- Spill level +375 m
- Dead storage 28.4 hm³
- Total capacity 237.6 hm³
- Useful storage 209.3 hm³
- Maximum area 8.4 km²
- Upstream watershed area 376.5 km²

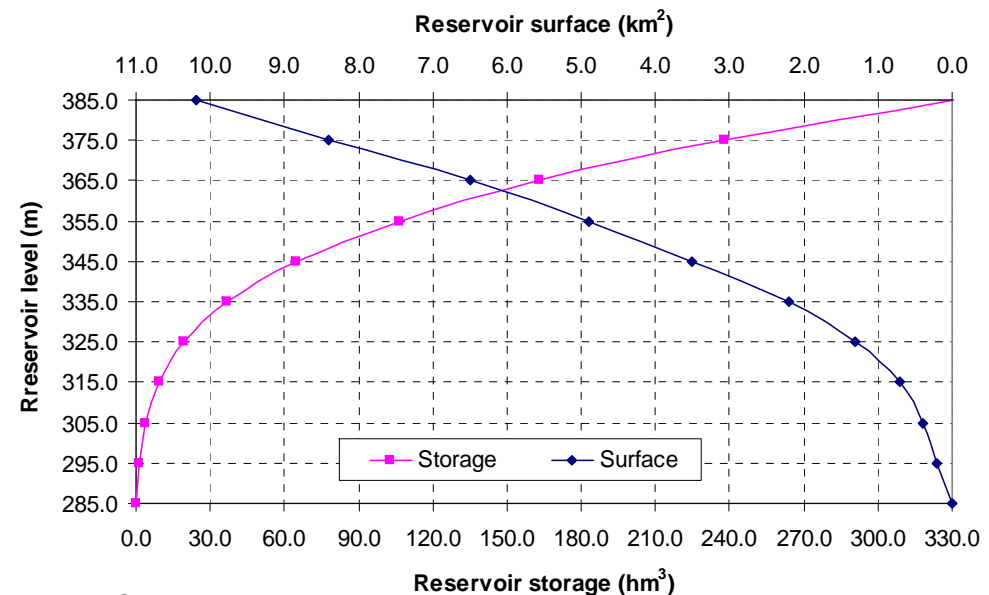

Level-storage-surface curves

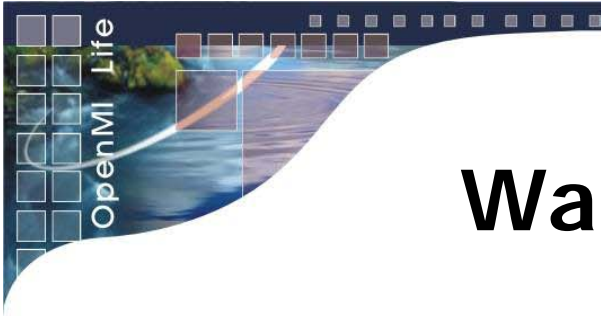

Water Uses (targets) and Operation Rules

- List of targets, ordered by priority:
 - Water release downstream of the reservoir for environmental preservation (10 hm³/y)
 - Abstractions through Leontari tunnel for water supply (15 hm³/y)
 - Abstractions through Leontari tunnel for irrigation (150 hm³/y)
 - Additional water release for irrigation (20 hm³/y)
- All targets but water supply are non-uniformly distributed during the dry period (April-September).
- The management of irrigation targets is employed on the basis of operation rules, assuming three reservoir level zones (<340 m, 340-350 m, >350 m) and corresponding rates of allowable water release (0, 50 and 100%).

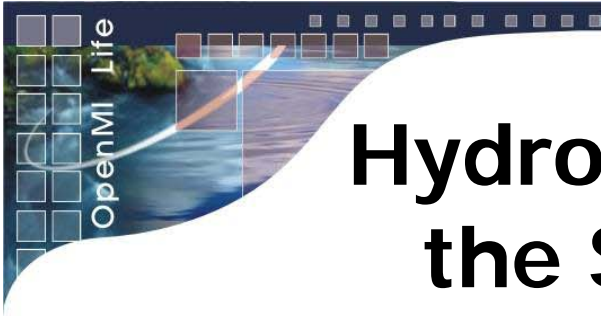

Hydrological Inputs Supporting the Simulation (time series)



- Simulation period: July 2002 – April 2007
- Simulation time step: 1 day
- Hydrological inputs are:
 - Inflow time series from the upstream watershed, provided by the MIKE11/NAM model (after calibration);
 - Rainfall depths, observed at Loutropigi station (located near the dam);
 - Evaporation depths, estimated on mean monthly basis and uniformly disaggregated.

Testing the Linkage

Model parameters were calibrated using observed inflows, estimated through the historical water balance of the reservoir.

- The calibrated model was well-fitted to the observed hydrograph

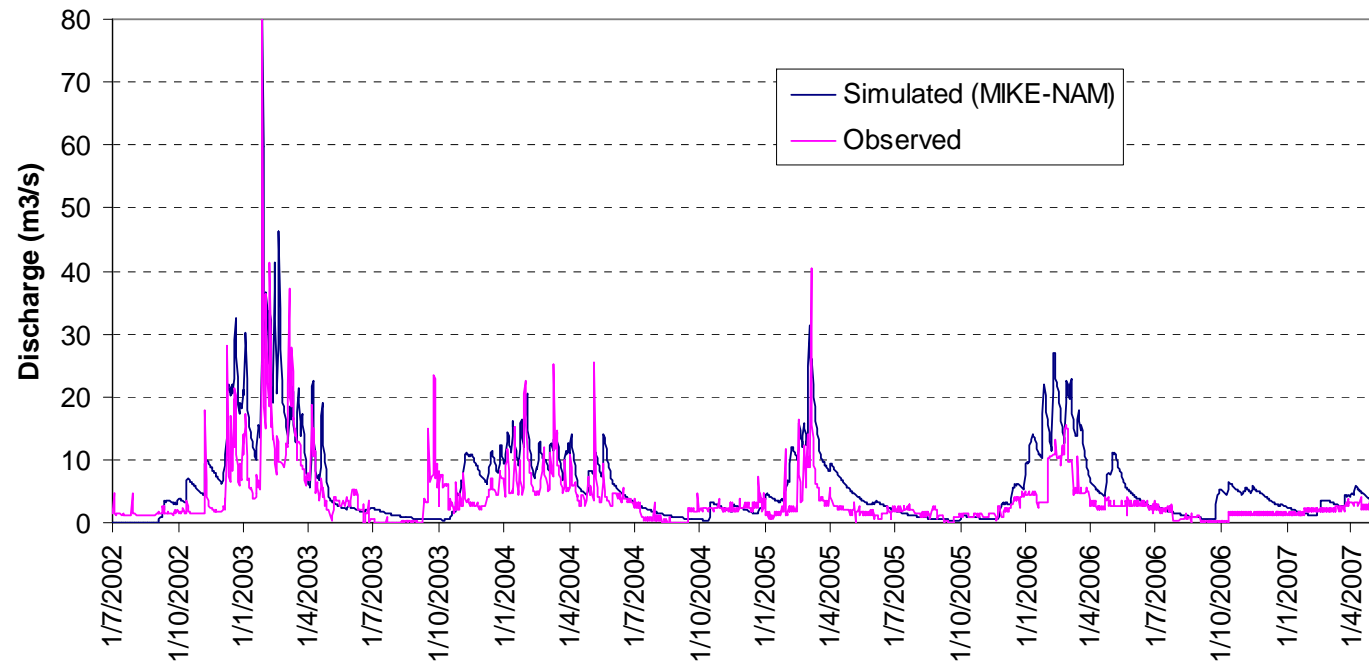
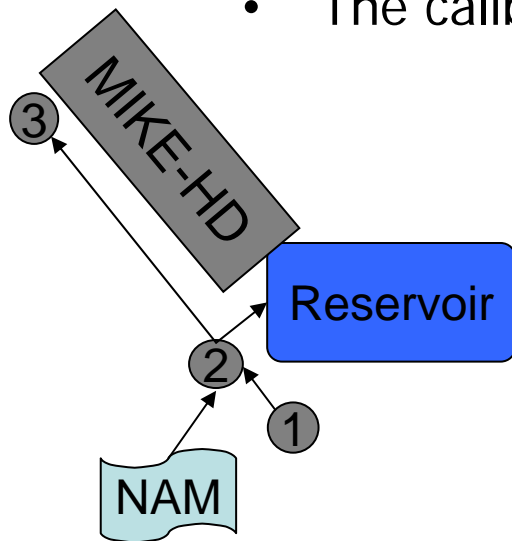

- The independent and linked model run results matched

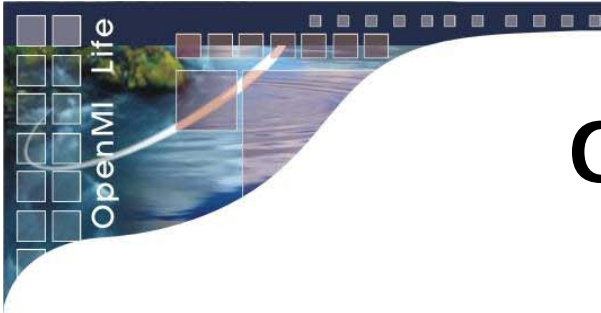

Generation of Climate Change Scenarios

- Climate change has multiple impacts on the entire hydrological regime, thus affecting the availability of water resources and, consequently, their management.
- Within the case study, three scenarios were examined, assuming 0% (normal), +10% (high) and -10% (low) change on historical precipitation depths.
- MIKE11/NAM was used to generate reservoir inflow scenarios, on the basis of modified precipitation series.
- Linked in OpenMI, the RMM-NTUA runs to generate the corresponding reservoir storage and outflow scenarios.

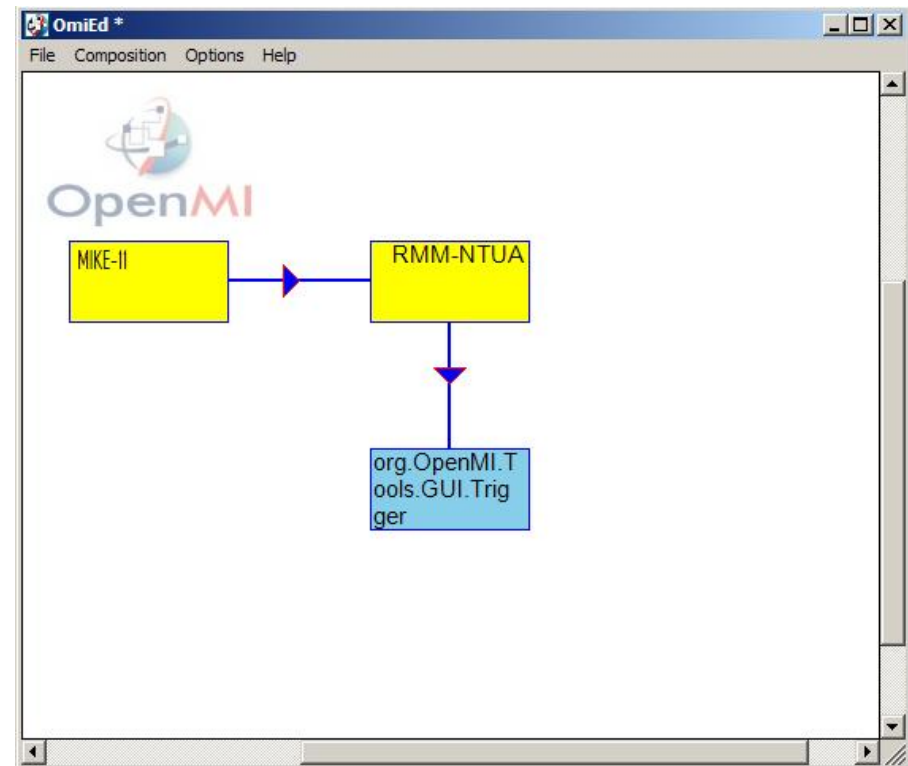

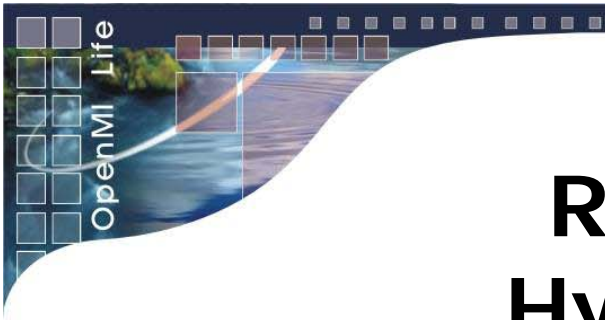

Results: Simulated Hydrological Inflows

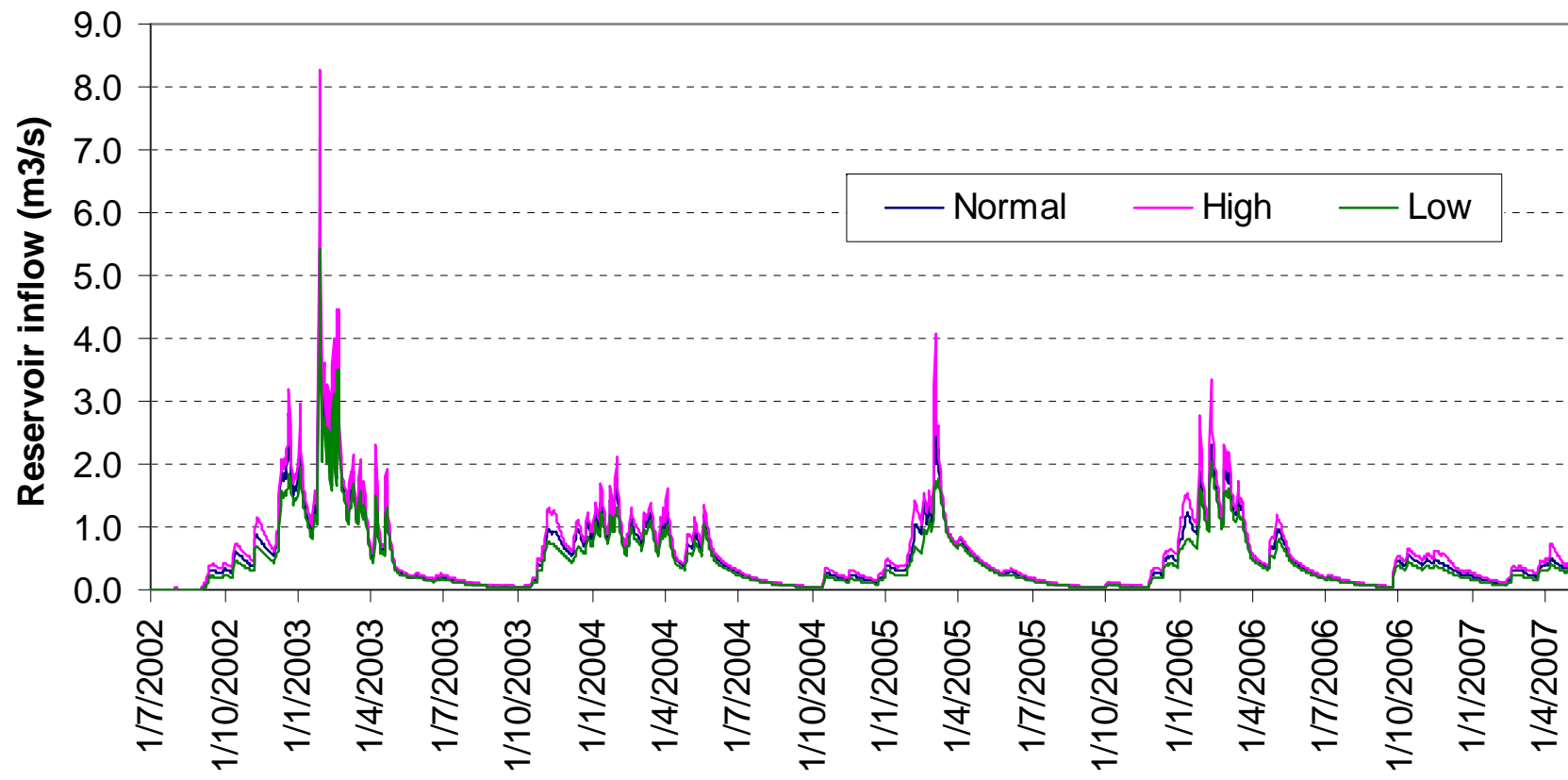

The 10% increase produces significantly higher flows at wet seasons



Results: Simulated Outflows^(*)

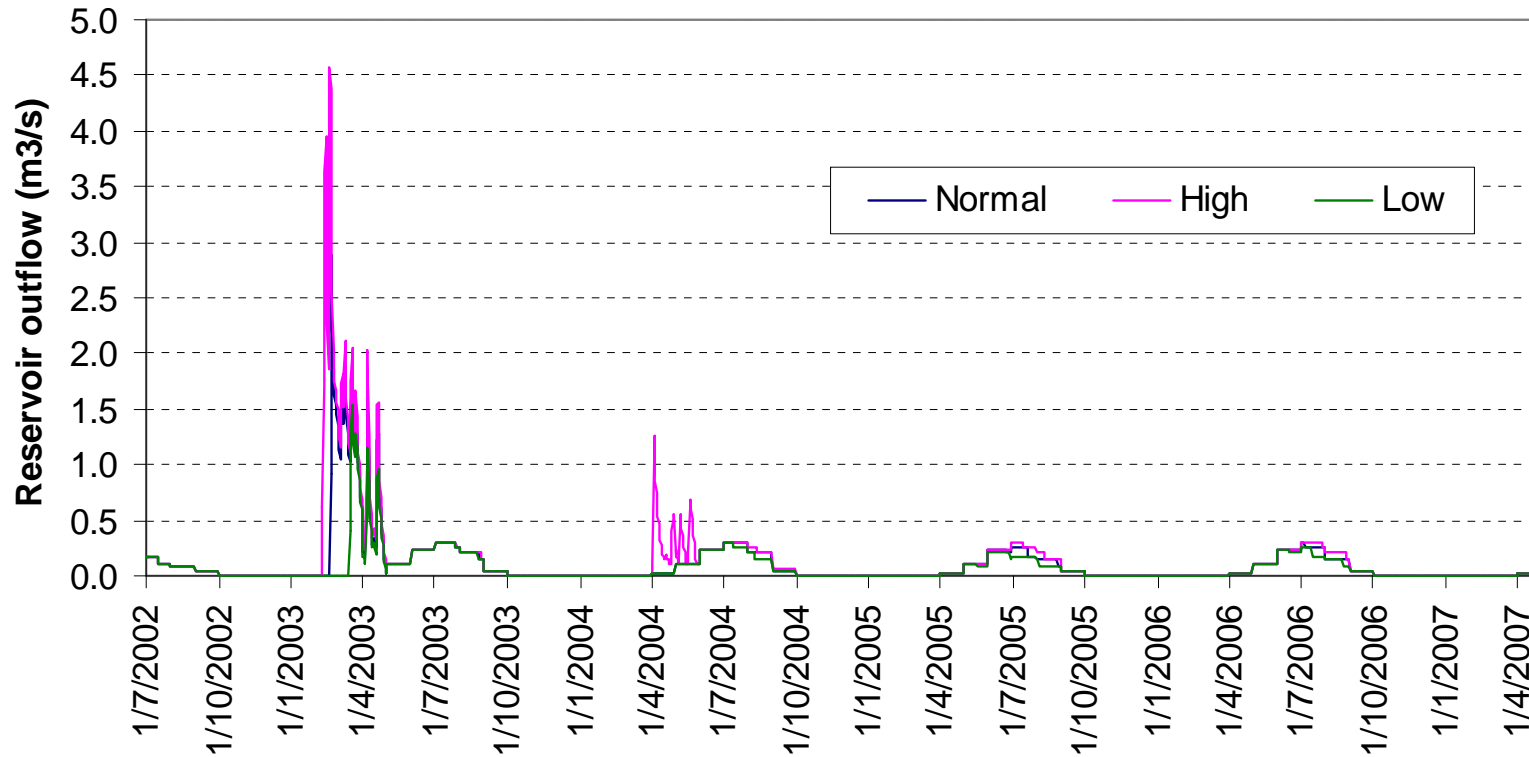

Accordingly, the outflows are much higher during intense events

() Outflow = downstream release for environmental preservation and irrigation + spills*

Results: Simulated Water Abstractions(*)

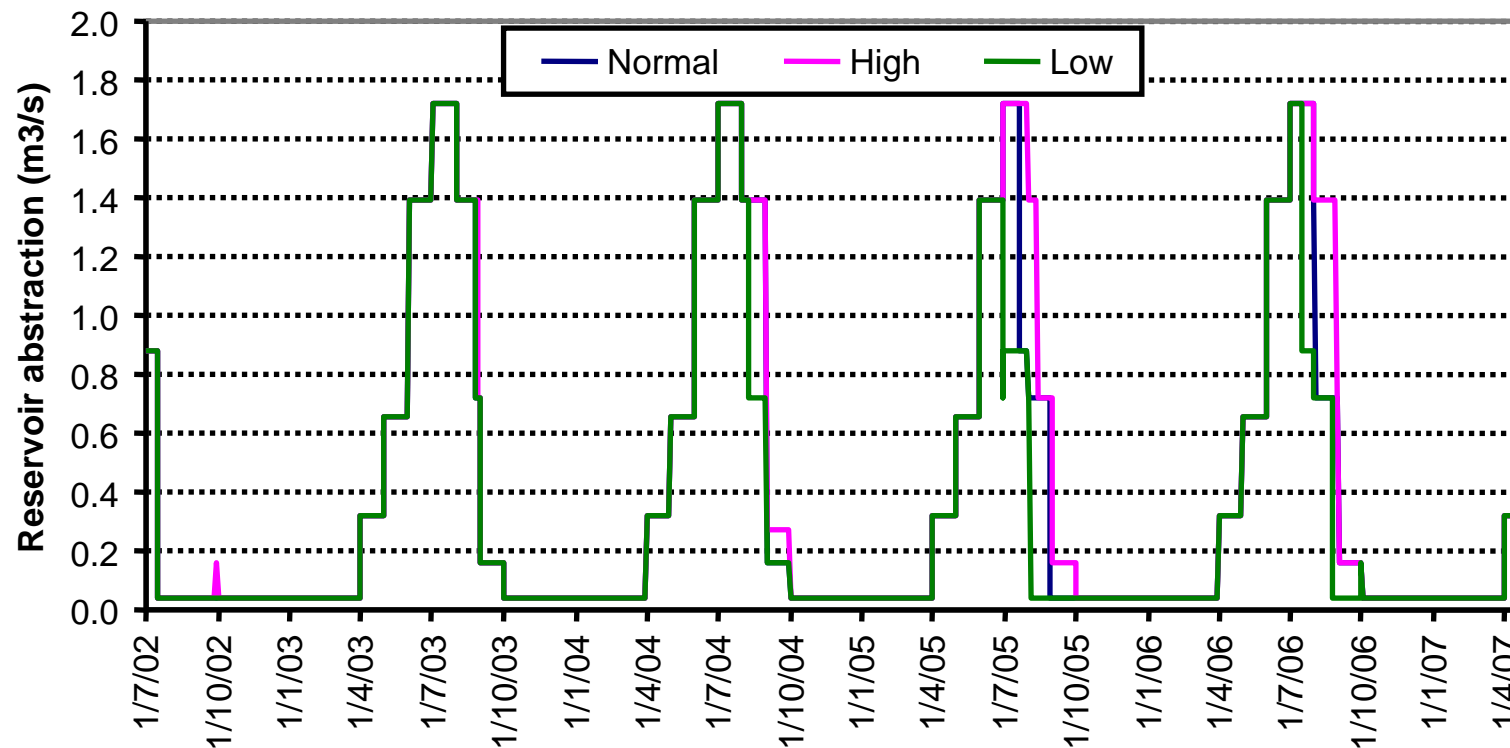

In dryer seasons, there is significantly less water to be allocated during spring and mainly summer for water supply and irrigation

(*) Abstraction = water diversion through Leontari tunnel for water supply and irrigation

Results: Simulated reservoir storage

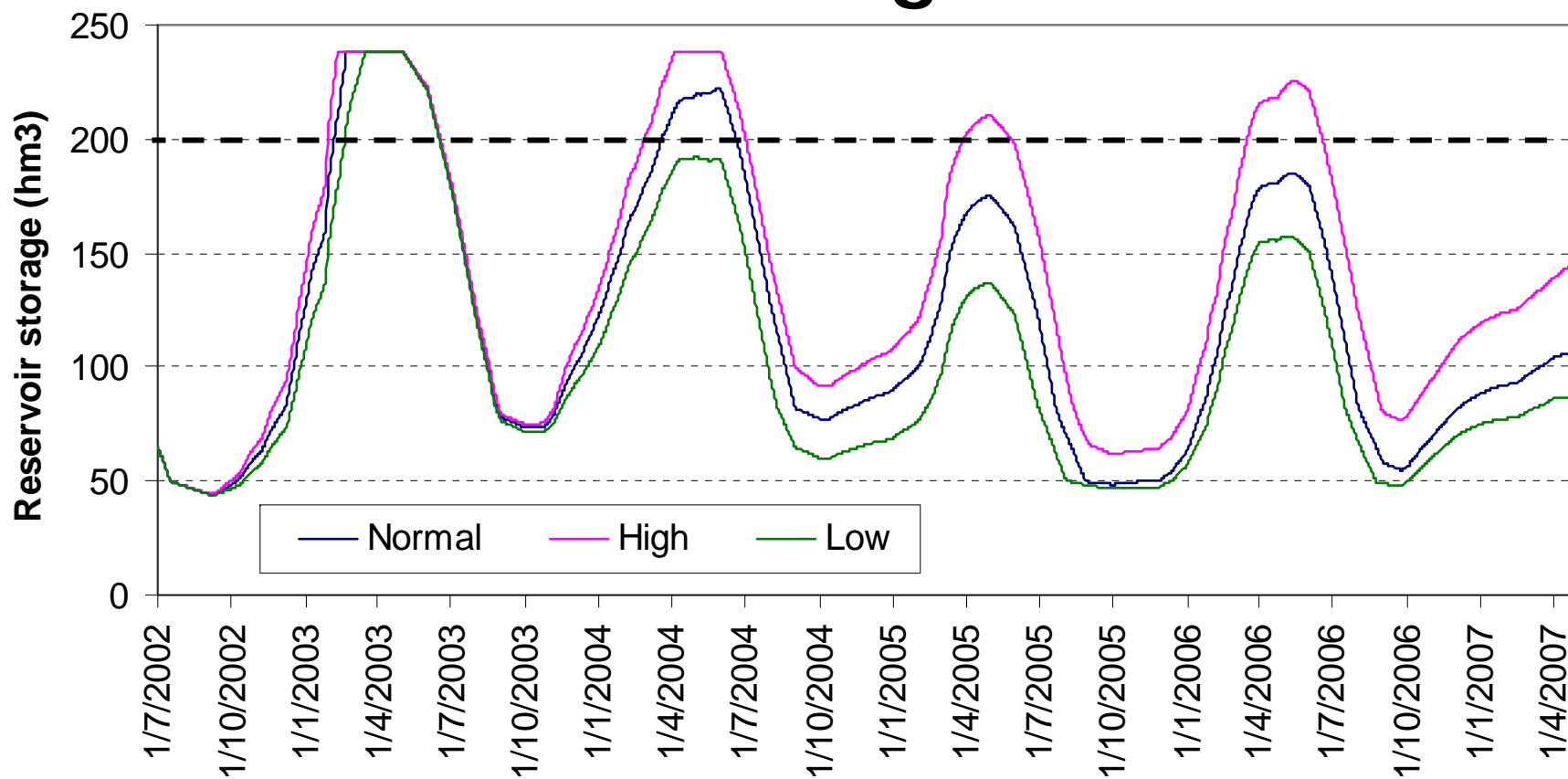

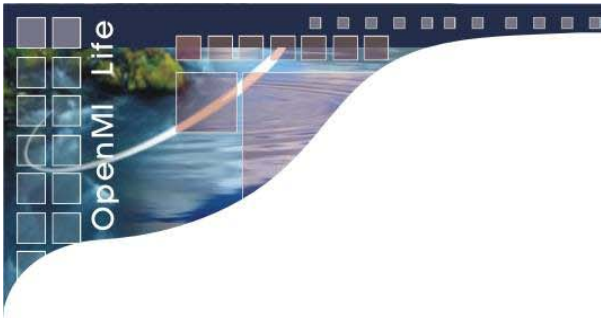

Conclusions



- The MIKE11/NAM and RMM-NTUA run independently and linked in OpenMI and prove that OpenMI can be applied to real world scenarios.
- The specific example aimed to provide a simple evaluation of possible impacts of climate change, by means of constant (10%) increase and decrease of precipitation depths, to the operation of the newly constructed Smokovo reservoir.
- Even a relatively small-scale change on precipitation affects notably the reservoir yield, as denoted through the 5-year simulation.

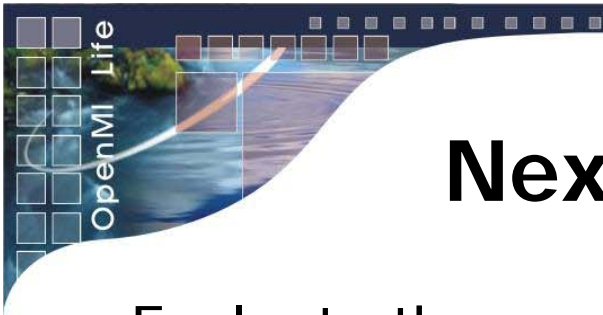

Next Steps of the Analysis

- Evaluate the use of OpenMI and real-time modelling in the operation of a system of two reservoirs supplying the same area
- Consider representing the hydraulic components of the upstream watershed with the use of MIKE-11
- Examine the actual climate change scenarios and their impact to the operation of the system
- Provide input to the Competent Authorities of the Thessaly Water District

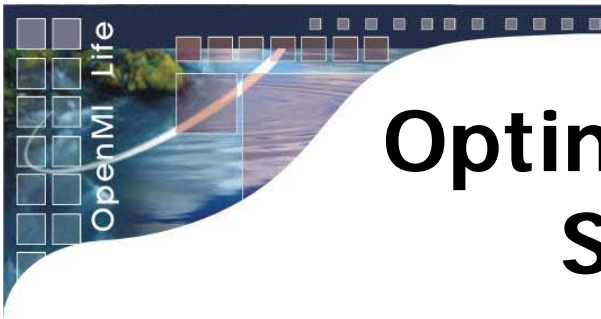

Optimizing the operation of a System of Reservoirs

